

Operations Manual



 **HUMMINBIRD**
PLATINUM ID

120

TABLE OF CONTENTS

INSTALLATION PREPARATION.....	2
Parts Supplied.....	2
Accessories.....	2
Installation Overview.....	2
Alternative Transducers and Mounting Methods.....	4
Transducer Exchange.....	5
INSTALLATION.....	6
Transom Installation.....	6
Inside the Hull Installation.....	10
Control Head Installation.....	12
Test the Installation.....	15
THANK YOU.....	16
USING THE PLATINUM ID 120.....	17
How the Platinum ID Works.....	17
Features.....	19
Operating Instructions.....	21
SPECIFICATIONS.....	28
MAINTENANCE AND WARRANTY.....	29
Maintenance.....	29
Troubleshooting.....	30
Warranty.....	33
Service Policy.....	34
Customer Support.....	35

INSTALLATION PREPARATION

PARTS SUPPLIED

PARTS SUPPLIED

Before installing your new Humminbird fishfinder, please ensure the following parts are included in the box:

- Fishfinder
- Transducer with 20' (6m) of cable and mounting hardware kit
- Mounting system and mounting hardware kit
- 6' (2m) power cable
- Publications kit

If any of these items is missing, call our Customer Support Hotline.

ACCESSORIES

Humminbird offers a wide assortment of accessories that complement and expand the capability of your new fishfinder. These accessories are designed with the same high standards and are backed by the same one-year warranty. The Humminbird Accessory catalog included with your unit contains descriptions of the many accessories available and ordering information. All Humminbird accessories are available through your full-service Humminbird dealer or factory direct through our number listed in the Customer Support section.

INSTALLATION OVERVIEW

Your Humminbird fishfinder consists of two primary components to install: the control head and the transducer.

The control head contains the sonar transmit and receive circuitry, as well as the user controls and display. It should be installed in a location that provides access to the controls and visibility while in use. The control head mounts on a quick disconnect mounting system that swivels and tilts providing flexibility for viewing from almost anywhere on the boat.

The transducer converts electrical energy from the transmitter into mechanical pulses or sound waves. The transducer also receives the reflected sound waves and converts them back into electrical signals for display on the control head. It should be installed in contact with the surface of the water in an area that has smooth waterflow- usually on the transom of the boat. There are several mounting options for the transducer. Review the following section to determine the method that works for you and your boat.

INSTALLATION PREPARATION

INSTALLATION OVERVIEW

Determining How to Mount the Transducer

Your Humminbird fishfinder includes a standard transducer. This transducer can be mounted on the transom of the boat or bonded to the inside of a fiberglass hull boat.

The transom installation, which is the most widely used, places the transducer on the outside of the boat hull. This technique produces the least signal loss, and provides a way to adjust the transducer after installation. The mounting hardware included is designed to protect both the boat and the transducer should the boat strike debris in the water or when trailering.

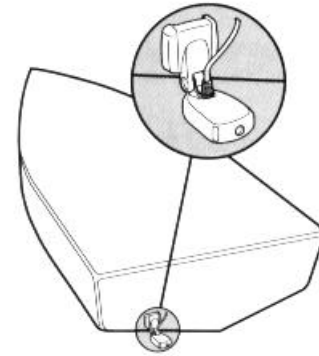

Transom Mounted Transducer

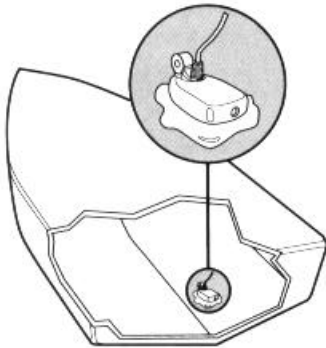

Inside the Hull Mounted Transducer

As an alternative to transom mounting, it is possible on many fiberglass-hulled boats to glue the transducer on the inside of the boat hull. Since fiberglass has similar sonar characteristics as water, the sonar signal can pass through the boat hull with minimal loss. The hull of the boat must be single layer construction (not double-hulled) Also, any air trapped in the lamination of the fiberglass would prevent the sonar signal from passing through.

Inside the hull installations require no holes be drilled into the boat and through experimentation, high-speed operation comparable to transom mounting can be achieved. Two-part slow cure epoxy (not included) is required to glue the transducer in place.

INSTALLATION PREPARATION

ALTERNATE MOUNTING METHODS

ALTERNATE TRANSDUCERS AND MOUNTING METHODS

Your Humminbird fishfinder comes with everything necessary for installation and operation on most boats. However, there are several situations which may require a different type of transducer. Inboard boats, wood or metal hulls, and sail boats create unique transducer mounting needs. Alternate transducers and mounting methods are detailed below.

Portable Mounting

The standard transducer can be adapted for portable installations with a portable mounting kit available from Humminbird. This accessory adapts your transducer to a suction cup mount for temporary installation on the boat hull or other surface.

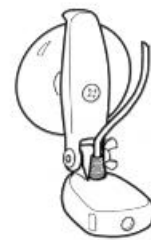

Trolling Motor Mounting

The standard transducer can also be adapted to mount on most trolling motors using a different accessory kit. This accessory includes a bracket and hose clamp that allows mounting the transducer to the body of most trolling motors.



Thru-Hull Mounting

Thru-hull transducers install through a hole drilled in the hull of the boat. Larger boats or boats with inboard motors create turbulence that make transom mounting ineffective. Also, hulls that are very thick or are double layered, or made from materials such as wood or metal, (which do not conduct sonar signals) make inside the hull mounting inadvisable.

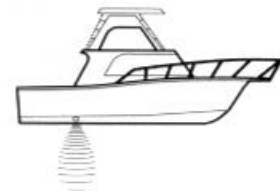

Thru-hull mounting may require the use of a fairing block to level the transducer with the waterline. Also, since special tools and knowledge may be required to perform this type of installation, it is best to refer to a qualified marine technician.

INSTALLATION PREPARATION

TRANSDUCER EXCHANGE

TRANSDUCER EXCHANGE

Other transducers are available as replacements for the standard transducer. You may exchange your new and unassembled transducer for another type by returning it to the address listed in Customer Support. Some transducers may have additional cost. Refer to the Accessory catalog or call Customer Support for information.

BEGINNING INSTALLATION

Now that you have determined the transducer mounting method you can begin installation of your new Humminbird fishfinder. The installation guide included on the next few pages provides detailed step by step instructions for installation of the control head and transducer. For transom mount transducer installations you will need the mounting template included with your manual.

In addition to the parts included you need the following for installation and operation:

- A powered hand drill and various drill bits
- Philips and flat-head screwdrivers
- A ruler or measuring tape
- Pen or pencil
- 12 volt power source (your boat's battery)
- A 1-amp fuse
- A fuse holder (if you are wiring directly to the boat's battery)
- Silicone sealant (for sealing drilled holes)
- 2-part, slow-cure epoxy (for inside the hull transducer installations)

INSTALLATION

TRANSOM INSTALLATION

Do not begin this transducer installation until you read the Installation Preparation in the Operation Guide. This chapter contains information critical to the correct installation of your transducer.

Due to the wide variety of boat hulls, only general instructions are presented in the installation guide. Each boat hull represents a unique set of requirements that should be evaluated prior to installation.

TRANSOM INSTALLATION

Step One - Determine Where to Mount the Transducer

Begin the transducer installation by determining where on the transom to install the transducer. Consider the following to find the best location:

- It is very important to locate the transducer in an area which is relatively free of turbulent water. As a boat moves through the water, turbulence is generated by the weight of the boat, and the thrust of the propeller(s). This turbulent water is normally confined to areas immediately aft of ribs, strakes or rows of rivets on the bottom of the boat, and in the immediate area of the propeller(s) (Figure 1). On outboard or inboard/outboard boats it is best to stay at least 15" (40cm) to the side of the propeller(s).
- If possible, viewing the transom of the boat while the boat is moving will provide the best means of locating turbulence free water. If maximum high-speed operation is a high priority, this is the recommended method. If this is not possible, select a location on the transom where the hull forward of this location is smooth, flat, and free of protrusions or ribs.
- The transducer when mounted should point straight down. The design of the transducer will accommodate a wide range of deadrises and remain ported straight down (Figure 2).
- On boats with stepped hulls, it may be possible to mount the transducer on the step. Never mount the transducer on the transom behind a step, as this area of the transom will not be in contact with the water at high speed (Figure 3).

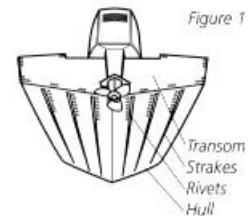

Transom Mounting Location

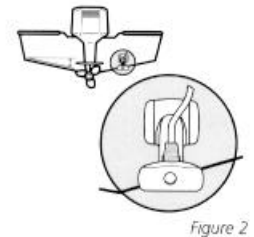

Figure 2

Stepped Hull

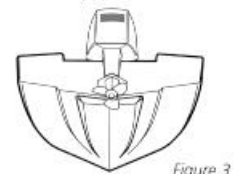

Figure 3

INSTALLATION

TRANSOM INSTALLATION

- If the propeller(s) is (are) forward of the transom, it may be impossible to find an area clear from turbulence, and a different mounting technique or transducer type should be considered.

Step Two - Drill the Mounting Holes

1. Remove the mounting template from the front of the Operations Manual.
2. Hold the template on the transom of the boat in the location where the transducer will be installed (Figure 4). Align the template vertically, ensuring the lower edge of the transom meets with the bottom corner of the template.
3. Using a pencil or punch, mark the two mounting holes shown on the template onto the transom. Do not mark or drill any other holes at this time.
4. Using a 5/32" (4mm) bit drill the two holes to a depth of approximately 1" (3cm). On fiberglass hulls, it is best to start with a smaller bit and use progressively larger drill bits to reduce the chance of chipping or flaking the outer coating.

Template alignment

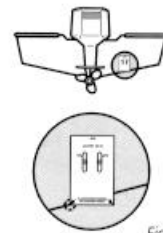

Figure 4

Transducer Assembly

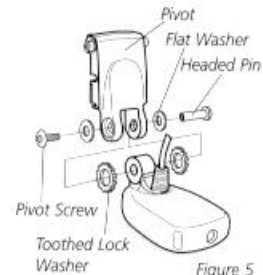

Figure 5

Step Three - Assemble the Transducer

1. Attach the Pivot to the transducer body as shown in Figure 5, using the #8 – 3/8" (9mm) long allen headed pivot screw, the headed pin, the two flat washers, and the two toothed lock washers.

Note: The toothed lock washers must be positioned between the transducer and the pivot ears. The flat washers must be positioned to the outside at the pivot ears.

2. Using the Allen wrenches provided, loosely tighten the pivot screw (Figure 6). Do not completely tighten the assembly at this time, so the pivot angle can be adjusted later.
3. Insert the pivot/transducer assembly into the mounting bracket as shown in Figure 7. Do not snap the assembly closed.



Figure 6

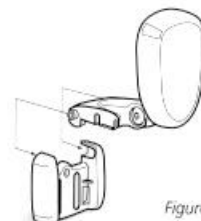

Figure 7

INSTALLATION

TRANSOM INSTALLATION

Step Four - Mount the Transducer to the Transom

1. Apply silicone sealant to the mounting holes drilled into the transom.
2. Align the transducer assembly with the drilled holes in the transom (Figure 8).
3. Use either a flat head screwdriver, a 5/16" (8mm) hex driver, or a 5/16" (8mm) socket to mount the assembly. Using the two #10 – 1" (25mm) long slotted hex head screws, mount the transducer assembly to the transom as shown. Do not fully tighten the mounting screws in order to vertically adjust the transducer. Snap the pivot down into place.



Figure 8

Step Five - Adjust the Running Position of the Transducer

The bracket allows height and tilt adjustment, the pivot screws allow angular adjustment. Initially, adjust the transducer as described in the following paragraphs. Further adjustment may be necessary to refine the installation after high speed testing.

1. First adjust the pivot angle of the transducer body so its length is parallel with the length of hull of the boat. Then pivot the transducer down so the rear is about 1/4 inch (6mm) lower than the front (Figure 9).
2. Fully tighten the two pivot screws using the Allen wrenches. It may be necessary to retighten the pivot screws after the initial use as the plastics may still be seating to the lock washers.
3. Adjust the height of the assembly so the face of the transducer is 3/16" (4.5mm) beneath the lower edge of the transom (Figure 10). Mark the position of the mounting bracket on the transom with a pencil.
4. Force the pivot to the up position to gain access to the mounting screws. Assure the transducer location has not changed, then fully tighten the two mounting screws (Figure 11). Snap the pivot back down.

Running Position Adjustment

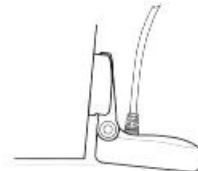
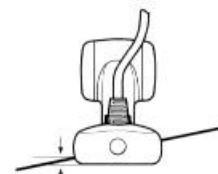

Figure 9



3/16" (4.5mm)

Figure 10

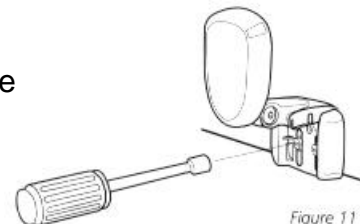

Figure 11

Confirm the pivot angle has not changed.

Note: A third screw location is provided for the mounting bracket. Drill this hole and install the screw after final testing and adjustments have been completed.

INSTALLATION

TRANSOM INSTALLATION

Step Six - Route the Cable

There are several ways to route the transducer cable to the area where the control head will be installed. The most common procedure routes the cable through the transom into the boat.

Inside the boat there is often a channel or conduit used for other wiring that the cable can be routed along. Do not cut or shorten the transducer cable and try not to damage the cable insulation. Route the cable as far as practical from the VHF radio antenna cables or tachometer cable to reduce the possibility of interference.

If the cable is too short, extension cables are available to extend the transducer cable up to a total of 50' (15 m). Call Humminbird Customer Support for more information.

Follow these steps to route the cable through the transom:

1. Drill a 5/8" (16mm) hole above the water line. Route the cable through the hole.
2. Fill the hole with silicone sealant.
3. Place the escutcheon plate over the hole and attach with the two #8 x 5/8" (16mm) screws.
4. Secure the cable by attaching the cable camp to the transom using a #8 x 5/8" (16mm) screw.

Note: The transducer will pivot up to 90 degrees in the bracket. Allow enough slack in the cable for this movement. It is best to route the cable to the side of the transducer so the cable will not be damaged by the transducer during movement.

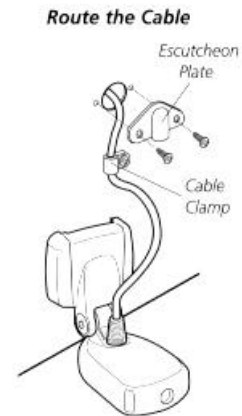

Figure 12

INSTALLATION

INSIDE THE HULL INSTALLATION

INSIDE THE HULL INSTALLATION

Inside the hull installation requires the mount system and control head be installed and operational. See Installing the Control Head for instruction on installing the unit.

Inside the hull mounting generally produces good results in single thickness fiberglass-hulled boats. Humminbird cannot guarantee depth performance when transmitting and receiving through the hull of the boat since some signal loss occurs. The amount of loss depends on hull construction and thickness, and the installation.

This installation requires slow-cure two-part epoxy. Do not use silicone or any other soft adhesive to install the transducer, as this material reduces the sensitivity of the unit. Five minute epoxy has a tendency to cure before all the air bubbles can be purged.

Step One - Determine the Mounting Location

Begin the transducer installation by determining where inside the hull to install the transducer. Consider the following to find the best location:

- Observe the outside of the boat hull to find the areas that are mostly free from turbulent water. Avoid ribs, strakes, and other protrusions as these create turbulence (Figure 14).
- As a general rule, the faster the boat can travel the further aft and closer to the centerline of the hull the transducer has to be located to remain in contact with the water at high speeds.

Step Two - Test the Mounting Location

There is no opportunity for adjustment after the transducer glued in place. Therefore, it is best to perform a trial installation on inside the hull transducers first, and run the boat at high speeds to determine the best mounting area.

1. At the identified mounting location, lay the transducer body face down with the pointed end towards the bow.
2. Fill the hull with enough water to submerge the transducer body. Use a sand filled bag or other heavy object to hold the transducer in position.

The transducer cannot transmit through air. The water purges any air from between the transducer and the hull and fills any voids in the coarse fiberglass surface.

Transducer Mounted
Inside the Hull

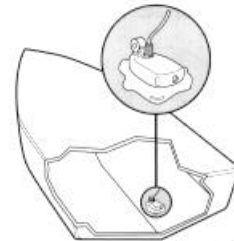

Figure 13

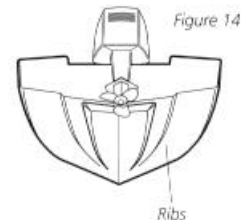

Figure 14

Preferred Mounting Area



Figure 15

INSTALLATION

INSIDE THE HULL INSTALLATION

3. Power up the Control Head.
4. Run the boat at various speeds and water depths while observing the screen on the Control Head. If the unit functions well at low speeds but begins to skip or miss the bottom at higher speeds, the transducer needs to be moved. If depth performance is required, test the fishfinder in water at the desired depth. Test different locations in the hull until the optimum performance is achieved.

Step Three - Permanently Mount the Transducer

1. Once the mounting location is determined, mark the position of the transducer.
2. Remove the water from inside the hull and thoroughly dry the mounting surface. If the surface is excessively rough, it may be necessary to sand the area to provide a smooth mounting surface.

Ensure the mounting area is clear and dry.

3. Mix an ample quantity of two-part slow-cure epoxy slowly and thoroughly. Avoid trapping air bubbles.
4. Coat the face of the transducer and the inside of the hull (Figure 16).
5. Press the transducer into place with a slight twisting motion to purge any trapped air from underneath, keeping the pointed end of the transducer body pointed forward (Figure 17).

Figure 16

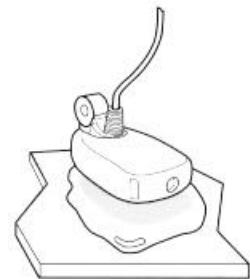
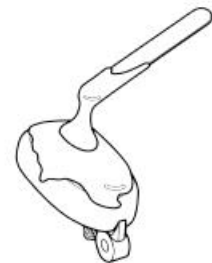

Figure 17

Note: Proper operation requires the pointed end of the transducer body to face towards the bow.

6. Weight the transducer so it does not move while the epoxy is curing.

When the epoxy cures, no water is necessary inside the hull. Neither water, spilled gasoline, or oil will affect the performance of the transducer.

INSTALLATION

CONTROL HEAD INSTALLATION

CONTROL HEAD INSTALLATION

Step One - Determine Where to Mount

Begin the installation by determining where to mount the control head. Consider the following to determine best location:

- The cables for power, transducer and temp/speed accessories (if applicable) should be installed first and must reach the mounting location. Extension cables are available.
- There are two ways to route the cables to the unit: through a hole in the mounting surface underneath the mounting bracket or from a hole outside the mounting bracket. Routing the cables down under the mount provides maximum weather protection; however this is not always feasible if the area under the fishfinder is inaccessible. In this case, route the cables through a hole at another location and cover with the supplied hole cover.
- The mounting surface should be adequately supported to protect the fishfinder from excessive wave shock and vibration, and provide visibility while in operation.
- The mounting area should allow sufficient room for the unit to pivot and swivel freely, and for easy removal and installation (Figures 18-19).

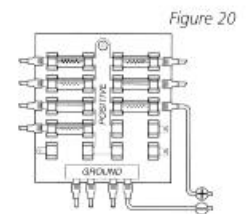
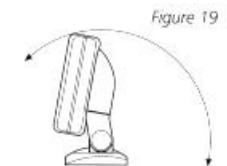
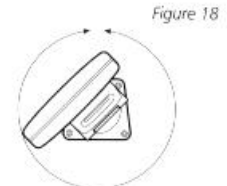

Step Two - Connect the Power Cable to the Boat

A 6' (2m) long power cable is included to supply power to the fishfinder. You may shorten or lengthen the cable using 18 gauge multi-stranded copper wire.

CAUTION: Some boats have 24 or 36 volt electric systems. Be sure your unit is connected to a 12 VDC power supply.

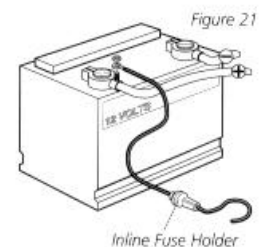

The Power can be connected to the boat's electrical system at two places: a fuse panel, usually located near the console, or directly to the battery.

If a fuse terminal is available, use crimp-on type electrical connectors (not included) that match the terminal on the fuse panel. Attach the black wire to ground, and the red wire to 12 VDC power (Figure 20). Be sure to use a one amp fuse in the connection. If you must wire the control head directly to a battery, be sure to install an inline fuse holder

INSTALLATION

CONTROL HEAD INSTALLATION

and one amp fuse (not included) for the protection of the unit (Figure 21). Humminbird is not responsible for over voltage or over current failures.

In order to minimize the potential for interference with other marine electronics a separate power source (such as a second battery) may be necessary.

Step Three - Drill the Mounting Holes

1. Set the mounting bracket in place on the mounting surface. Mark the four mounting screw locations with a pencil or punch.
2. Set the mounting bracket aside, and drill the four mounting screw holes using a 9/64" (3.6mm) bit.

Step Four - Run the Cables

1. If the cables must pass through a hole underneath the mounting surface, mark and drill a 1" (25mm) hole centered between the four mounting holes (Figure 22).

Note: if the cables must pass through the mounting surface at a different location, drill the 1" (25mm) hole at that location and pass the cables through from underneath. Also, you must break out the tabs on the rear of the mounting base using needle nose pliers (Figures 24-25).

2. Insert all cables through the 1" (25mm) hole from beneath the mounting surface.
3. Pass the cables through the grommet (if the cable hole is underneath the mounting bracket) then press the grommet in place around the cables and into the 1" (25mm) hole.
4. Pass the cables through the mounting base, out the top of the mounting bracket.
5. Place the mounting bracket on the mounting surface aligned with the drilled holes. Insert the four flathead wood screws into the mounting holes and tighten fully (Figure 23).

Optional: If the cables pass outside the mounting bracket, install the hole cover over the hole and fasten in place using the two #8 x 7/8" (22mm) wood screws (Figure 24).

Figure 22

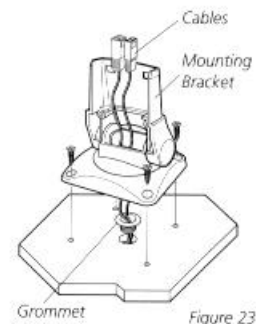
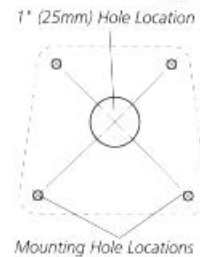

Figure 23

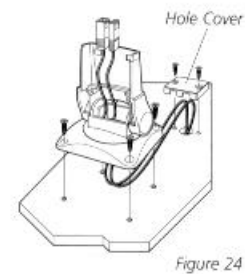

Figure 24



Figure 25

INSTALLATION

CONTROL HEAD INSTALLATION

Step Five - Assembling the Connector Holder

1. Insert the cable connectors into the connector holder. The cable connectors are labeled, and there are corresponding labels on the connector holder (Figure 26). The slots for the connectors are keyed to prevent reverse installation, so do not force the connector into the holder.
2. Carefully pull the excess cable from beneath the - mounting surface so the connector holder aligns with the mounting holes on the front of the mounting bracket (Figure 27).
3. Snap the support plate to the rear of the connector holder (Figure 28).
4. Insert the connector holder into place and use the two #6-32 x 3/4" (9mm) screws to fasten it to the mounting bracket (Figure 28).
5. Install the control head by sliding it onto the mounting bracket until it is fully seated. To remove the unit simply depress the latch on the rear of the unit and lift (Figure 29).

Your Humminbird is now ready for operation.

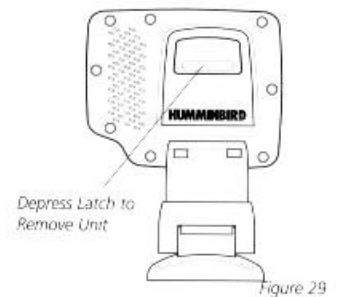
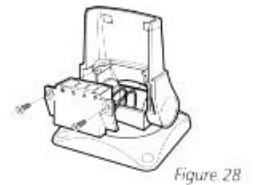
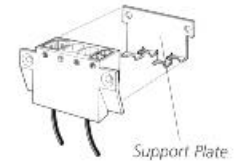
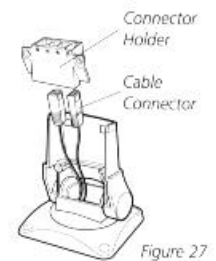
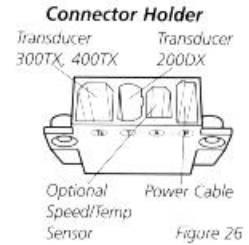

INSTALLATION

TEST THE INSTALLATION

TEST THE INSTALLATION

Testing should be performed with the boat in the water, however you can initially confirm basic operation with the boat trailered.

Press POWER once to turn the unit on. There will be an audible chirp when any button is pressed to confirm the button press. If the unit does not power-up, ensure the unit is fully seated on the mount and that power is available.

The first screen provides four options: Start-up, Options, Simulator, and Diagnostic. A message at the bottom of the screen indicates the transducer connection. If no transducer is detected (or one is not connected), the message will indicate this and the unit will go into simulator after the initial screen times out.

Note: the transducer must be submerged in water for reliable transducer detection.

If a transducer is detected, the unit will enter "Start Up" or normal operation unless you choose another option. If you do not press any button before the timer reaches "0", the normal operation screen is displayed. If the boat is in water, sonar data appears.

If the bottom is visible on screen with a digital depth readout, the unit is working properly. Ensure the boat is in water greater than 2' but less than the depth capability of the unit and the transducer is fully submerged. Remember the sonar signal cannot pass through air.

If the unit is working properly gradually increase the boat speed to test high-speed performance. If the unit-functions well at low speeds but begins to skip or miss the bottom at higher speeds, the transducer requires adjustment. Refer to the appropriate transducer installation section for more detail.

Note: it is often necessary to make several incremental transducer adjustments before optimum high-speed performance is achieved.

Important: For Transom Mount transducer installations, install the third mounting screw after the final transducer adjustments.



Humminbird • 3 Humminbird Lane • Eufaula, Alabama 36027

THANK YOU

THANK YOU

Thank you for choosing Humminbird, America's #1 name in depth sounders. Humminbird has built its reputation by manufacturing top quality, thoroughly reliable marine equipment. Your Humminbird is designed for trouble-free use. We encourage you to read this operations manual carefully in order to get full benefit from your Humminbird and all its features and uses. Also, to register your purchase and ensure complete warranty coverage please take a few minutes to register your new product with us. This can be done quickly and easily through our website at www.humminbird.com.

NOTE: Your Platinum ID 120 is completely waterproof - simply hose it off to remove dirt or salt. Periodically check the gold connector contacts on the back of the unit: deposits, particularly from salt water, can cause a faulty connection and interfere with performance. (For complete maintenance tips, please see the Maintenance section in this manual.

WARNING: This device should not be used as a navigational aid to prevent collision, grounding, boat damage, or personal injury. When the boat is moving, depth may change too quickly to allow time for you to react. Always operate the boat at very slow speeds if you suspect shallow water or submerged objects.

USING THE PLATINUM ID 120

HOW SONAR WORKS

HOW SONAR WORKS

There are two main components to a Platinum ID installation: the sensor, which you will install on the transom or inside the hull, and the Platinum ID unit. The sensor and Platinum ID communicate by means of a cable, and are powered by your boat's 12-volt DC battery.

The sensor and Platinum ID use the basic principles of sonar to reveal objects beneath the water's surface.

The Platinum ID continuously sends electronic signals to the sensor, which converts them to ultrasonic signals that it aims toward the bottom. Each signal travels downward until it strikes an object or the bottom, then immediately echoes back to the sensor. As the sensor receives these signals, it converts them back to electronic signals for display on the Platinum ID screen.

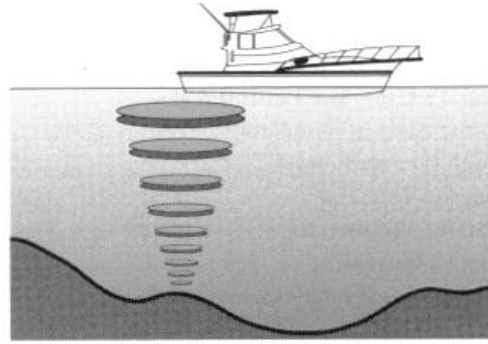
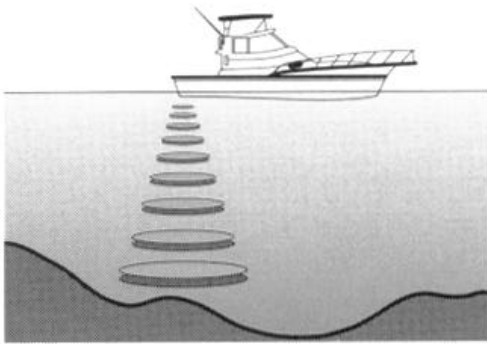

USING THE PLATINUM ID 120

HOW SONAR WORKS

The Platinum ID uses the returned signals to display a detailed underwater image, and constantly updates the display as you travel across the water. The display informs you of the current depth and reveals individual fish, schools of fish, their location, bottom details as well as bottom hardness.

An easy-to-use control also lets you enable a depth alarm for an audible alert when the boat is in shallow waters.

The Platinum ID incorporates the best of available technologies, and offers advantages you won't find in other depth sounders.

The liquid crystal display offers sharp viewing even in bright, direct sunlight, and is backlit for nighttime operation. Advanced LCD "super-twist" technology built into the Platinum ID offers a wider viewing angle and higher contrast than ordinary LCD screens.

(You will notice that the display can be seen better at certain angles. The All-in-One Mounting System lets you easily adjust the viewing angle for optimum viewing. Note also that some polarized glasses can affect your view by causing a rainbow or prism to appear; if so, tilt the unit slightly.)

Though it includes sophisticated electronics, the Platinum ID is tough enough to take the pounding punishment of rough seas or a race across the lake. Completely waterproof - even saltwater-proof – your Platinum ID will provide you with years of thoroughly reliable operation.

In the unlikely event that your Humminbird does require repairs, we offer an exclusive Service Guarantee. Complete details are provided at the end of this manual.

USING THE PLATINUM ID 120

PLATINUM ID FEATURES



POWER: Press the button once to turn the Platinum ID on, then press again to turn the unit off. When the unit is off, keeping POWER pressed for about two seconds starts the built-in simulator.

STOP: Freezes the action on screen so that it can be studied more closely or to allow more time to adjust menu functions.

LIGHT: Activates the backlight for nighttime use.

SELECT: Allows the user to select between menu functions that are displayed on the screen.

UP-DOWN: Is used for adjustment of the menu functions.

ON-OFF: Turns the menu functions on and off.

The latch is used to remove the Platinum ID from the swivel mount. To use simply press the bar and lift the unit from the mount.

The Connector System cover is used to facilitate mounting of the Platinum ID unit. With the connector in place, all of the cables are held securely in place so that the unit can be easily removed and mounted.

The All-in-One Mounting System for the Platinum ID allows for complete control of unit placement. The base swivels a full 360 degrees so that the unit is always at the optimal viewing angle. Also, the bracket has a ratchet mechanism that allows the unit to be tilted backward and forward to achieve the best viewing angle for different heights.



USING THE PLATINUM ID 120

OPERATING INSTRUCTIONS

OPERATING THE PLATINUM ID

This section provides complete information on operating the Platinum ID through its front panel controls. You are encouraged to read this information completely as you first learn to use the Platinum ID; doing so will ensure you make the most of its many features and functions.

The first part of this section explains the use of the built-in simulator, which you can use to practice selecting instructions through the front panel. The remaining instructions, which can be followed while using the simulator or in actual operation, explain each function and are organized according to the front panel layout.

The Platinum ID includes a built-in simulator that helps you learn to use your new equipment. The simulator displays a typical underwater scene, and lets you practice with the controls.

USING THE BUILT-IN SIMULATOR

The unit must be powered off before you start the simulator. To activate it, press down and hold the POWER button until a chirping sound begins. Release the button, and the built-in simulator begins displaying a typical Platinum ID reading.

You can use the simulator to learn the functions explained in the following pages, just as if you were getting actual on-the-water readings (but note that "Sensitivity" is disabled). To turn off the simulator, turn off the unit by pressing the POWER button again.

Of course, the best way to learn to use the platinum ID is with actual use, especially in familiar waters. If you know what's below and see it on-screen, you'll quickly become a Platinum ID expert.

USING THE PLATINUM ID 120

OPERATING INSTRUCTIONS

PLATINUM ID FUNCTIONS

POWER



STOP



LIGHT



SELECT



ON-OFF



The Platinum ID offers several functions that you can adjust with the front panel buttons. (Note that to select something with a button, you must press it fully so that you can hear a “chirp” sound.)

You can get acquainted with these features by actual operation, or when using the simulator.

POWER: Press the button once to turn the unit on, then press the button again to turn the unit off. When the unit is off, keeping POWER pressed for about two seconds starts the built-in simulator.

STOP: Press this button to “freeze” the display so you can study it. Press it again to restart the display movement.

SELECT: This button is used to access the following functions for further adjustment:

- ID
- Units
- Sensitivity
- Bottom Alarm
- Fish Alarm
- Zoom Range
- Bottom Lock
- Display Speed
- Depth Range
- Trip Log

To adjust any of these, press SELECT until the function you want appears. Each function’s display tells you how to use the arrow buttons and ON-OFF for adjustment; when first using, you should also refer to the following instructions.

USING THE PLATINUM ID 120

OPERATING INSTRUCTIONS

The three position bottom hardness scale at the bottom of the screen helps differentiate between grass or muddy (soft) bottoms and structure or rock (hard) bottoms.

After you adjust any function, the display returns to its full-screen reading. If the menu doesn't stay on the screen long enough, press the STOP button to hold the menu on the screen.

NOTE: The last function you select remains "active" – that is, you can adjust it without having to press SELECT again. For example, if the bottom alarm was the last function used, you can readjust the alarm by pressing one of the arrow buttons. Or, if you often use Zoom, you can select it once, then switch it on and off by simply pressing ON-OFF.

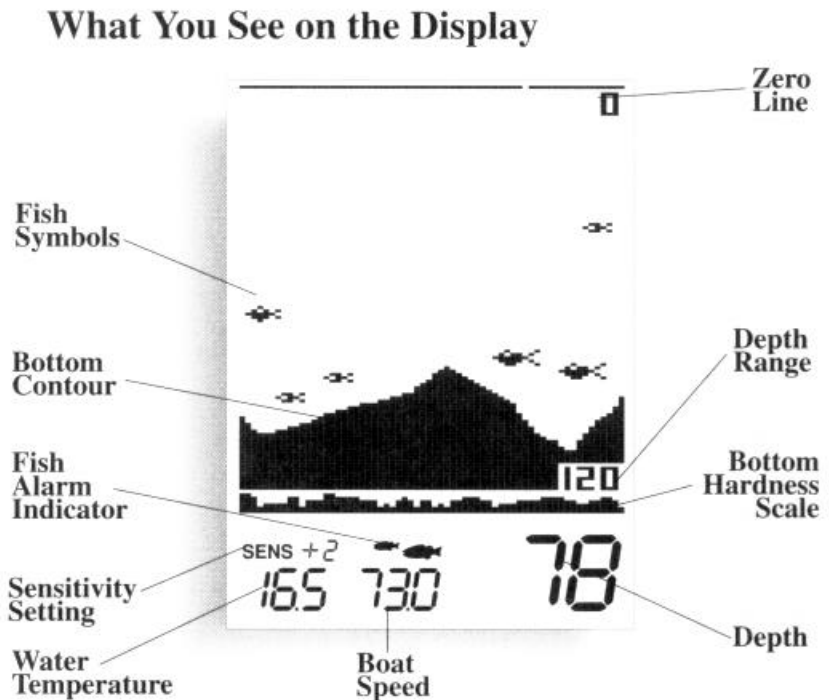

USING THE PLATINUM ID 120



OPERATING INSTRUCTIONS

1. Selecting ID

Factory Setting: Fish Symbols

ID identifies targets not attached to the bottom and displays them with either a fish symbol or an arch. Three different size fish symbols are used to represent the returned signal strength, a good indicator of fish size. Use the up and down arrow keys to switch between fish or arches, or use the ON-OFF switch to disable ID.



  Selects ID symbol
 Enables ID

2. Selecting Units

Factory Setting: MPH/SM

If you are using the trolling speed accessory with your Platinum ID, you can switch the units of measurement between miles per hour (MPH) or knots (KTS). This selection also affects Trip Log where recorded distance will be displayed in statute miles (SM) or nautical miles (NM).



  Selects Units

USING THE PLATINUM ID 120

OPERATING INSTRUCTIONS

3. Selecting Sensitivity

Factory Setting: +0

The Platinum ID automatically adjusts to the proper amount of sensitivity for conditions (ie depth). You can bias the setting + or – 5 levels to suit your personal taste. Increasing the sensitivity adjustment can cause the display of very small targets and thermoclines which might not be displayed at the +0 setting.

If you want to manually adjust Sensitivity, select SENS and press the Up or Down arrow button to adjust the display.

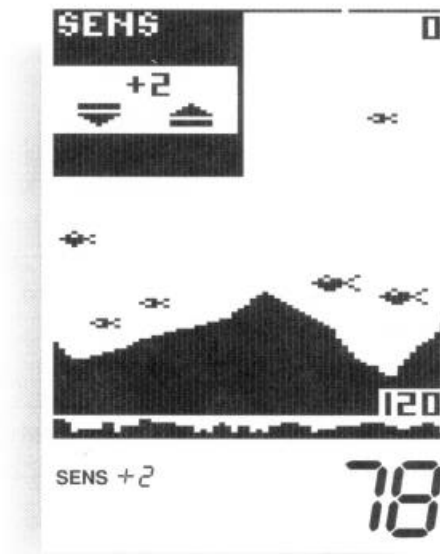

  Adjusts sensitivity



4. Enabling Bottom Alarm

Factory Setting: OFF

The Bottom Alarm lets you specify the minimum depth you want to maintain. To use it, select BOTTOM ALARM; then press the ON-OFF button to activate the alarm, and the Up or Down arrow button to adjust the depth at which the alarm will sound. A dashed line appears at the alarm depth when the function is on.

When Bottom Alarm is on, you'll hear a continuous chirping sound when the bottom is shallower than you defined. This is very handy for alerting you to shallow water or helping you to maintain position over structure.



  Adjusts alarm depth
 Enables alarm

USING THE PLATINUM ID 120

OPERATING INSTRUCTIONS

5. Enabling Fish Alarm

Factory Setting: OFF

The Fish Alarm alerts you with a chirping sound whenever the Platinum ID detects fish (or another object not attached to the bottom). To activate it, select FISH ALARM and press the ON-OFF button.

Initially, the fish alarm will sound when any target not attached to the bottom is detected. The word "ALL" is displayed on the menu and two fish are shown at the lower part of the display. By pressing either arrow button, the word "LARGE" appears and the alarm will sound only when a large target is detected. A single fish symbol is shown on the bottom of the display to represent that large fish only is selected. While there is some variation in sonar characteristics of different species, typically, the strength of the return is relative to the size of the fish.



Selects all or large
 Enables alarm

6. Using Zoom Range

Factory Setting: OFF

Zoom Range provides an up-close view. To activate it, select ZOOM RANGE and press ON-OFF. The Zoom view begins initially at the surface; press the Up or Down arrow to adjust Zoom depth. The range of the display is shown when Zoom is on.

The Zoom range depends on the current Depth Range: 7 ½' in the 15' and 30' Depth Ranges; 15' in the 60' and 120' Depth Ranges.

You can adjust zoom depth before activating zoom, in which case the zoom range will be shown with horizontal dotted lines.



Selects zoom depth
 Enables zoom

USING THE PLATINUM ID 120

OPERATING INSTRUCTIONS

7. Using Bottom-Lock

Factory Setting: OFF

Bottom-Lock provides an up-close view like Zoom Range, except that in this case the zoomed view automatically moves up or down to stay on the bottom. To use this feature, select BOTTOM LOCK and press ON-OFF. The range of the display is shown when Bottom-Lock is on.

This is an ideal feature for finding structure or locating fish near the bottom.

Remember: If Bottom-Lock is the last function you selected, you can use the ON-OFF button to switch Bottom-Lock on and off without having to press SELECT first.



ON-OFF Enables bottom-lock

8. Display Speed

Factory Setting: One level below maximum

The Platinum ID is “updated” (advances across the screen) as you move through the water. The speed at which the display is updated depends on the Display Speed setting. To adjust it, select DISPLAY SPEED, and press the Up arrow button for a faster setting or the Down arrow button for a slower setting.

In general, higher Display Speed settings provide faster updates, while slower Display Speeds provide more detailed information.

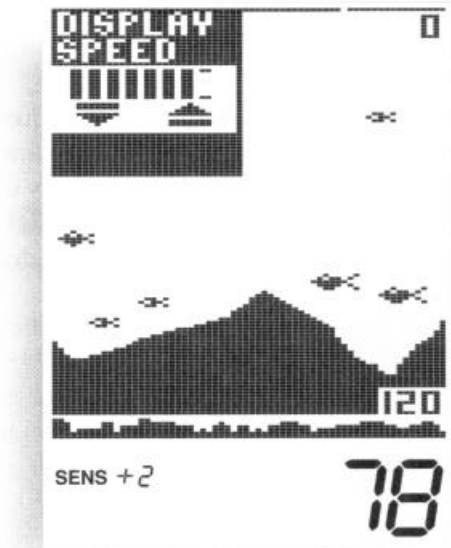

Adjusts speed

USING THE PLATINUM ID 120

OPERATING INSTRUCTIONS

9. Setting Depth Range

Factory Setting: ON (Automatic)

When you turn the Platinum ID on, it finds the bottom, sets the ideal Depth Range, and automatically adjusts the Depth Range (to as much as 120') as the depth changes. In this "Auto Depth Range" mode, the bottom is blacked-in for easy-to-understand readings.

If you prefer, you can turn Auto Depth Range off. Select DEPTH RANGE, press ON-OFF, and adjust the Depth Range with the Up or Down arrow button.

In this "Manual Depth Range" mode, the bottom is not blacked in. This lets you see a "second return," which is preferred by some fishermen because the width of the second echo can indicate bottom hardness.

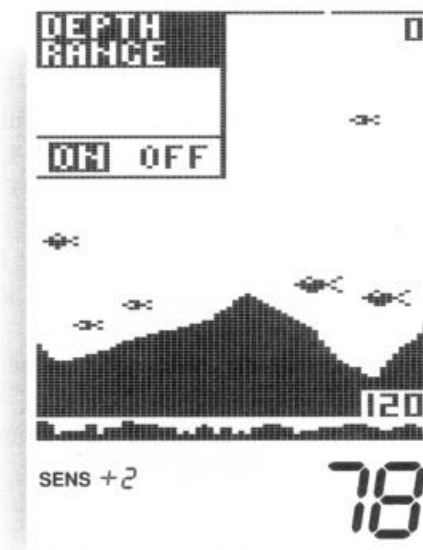

▼ ▲ Selects depth range
ON-OFF Enables auto range

10. Trip Log

Factory Setting: OFF

The Platinum ID Trip Log provides a full screen of information on current conditions. To display it, select TRIP LOG and press ON-OFF.

All log information is continuously updated as long as the platinum ID remains powered on. If you want to reset Average Speed, elapsed time, and Elapsed Distance, press the STOP button.

Pressing ON-OFF exits the Trip Log and returns you to normal Platinum ID operation.

NOTE: Trip Log requires proper input from the speed accessory on the transom of the boat.



STOP Resets timer
ON-OFF Enables timer

SPECIFICATIONS

Operating Frequency	455KHz
Power Requirement	10-16 volts DC
Power Cable Length	48"
Sensor (standard)	SHS6-16
Sensor Cone Angle	16 degrees
Depth Range	0-15', 0-30', 0-60', 0-120'
Unit Construction	High-impact polycarbonate housing
Unit Dimensions	6 ½" W x 6 ¾" H x 1 ½" D
Display	Super-twist LCD
Viewing Area	3.1" x 4.1"
Matrix Configuration	64 x 125

MAINTENANCE AND WARRANTY

MAINTENANCE

MAINTENANCE

Your Humminbird fishfinder is designed to provide years of trouble free operation with virtually no maintenance. Follow these simple procedures to ensure your Humminbird continues to deliver top performance.

- If the unit comes into contact with salt spray simply wipe the affected surfaces with a cloth dampened in fresh water. Do not use a chemical glass cleaner on the lens. Chemicals in the solution may cause cracking in the lens of the unit.
- When cleaning the LCD protective lens, use a chamois and non-abrasive, mild cleaner. Do not wipe while dirt or grease is on the lens. Be careful to avoid scratching the lens.
- If your boat remains in the water for long periods of time, algae and other marine growth can reduce the effectiveness of the transducer. Periodically clean the face of the transducer with liquid detergent. Pivoting the transducer up in the bracket may allow better access for inspection or cleaning.
- If your boat remains out of the water for a long period of time, it may take some time to wet the transducer when returned to the water. Small air bubbles can climb to the surface of the transducer and interfere with proper operation. These bubbles dissipate with time, or you can wipe the face of the transducer with your fingers after the transducer is in the water.
- Never leave the fishfinder in a closed car or trunk - the extremely high temperatures generated in hot weather can damage the electronics.

MAINTENANCE AND WARRANTY

TROUBLESHOOTING

TROUBLESHOOTING

Do not attempt to repair the fishfinder yourself. There are no user serviceable parts inside, and special tools and techniques are required for reassembly to ensure the waterproof integrity of the housing. Repairs should be performed only by authorized Humminbird technicians.

Many requests for repair received by Humminbird involve units that do not actually need repair. These units are returned “no problem found.” If you have a problem with your Humminbird, use the following troubleshooting guide before calling Customer Support or sending your unit in for repair. Your Humminbird fishfinder contains several tools that can aid in determining if there is a problem and how to isolate and repair the problem in many cases.

1. *Nothing happens when I turn the unit on.*

Check the power cable connection at both ends. Be sure the cable is connected correctly to a reliable power source - red lead to positive, black lead to negative or ground. Ensure the power available at the mount is between 10 and 20 VDC. If the unit is wired through a fuse panel, ensure the panel is powered. Often accessory fuse panels are controlled by a separate switch or the ignition switch. Also, often a fuse can appear to be good when in fact it is not. Check the fuse with a tester or replace it with a fuse known to be good.

Check the power connection to the unit. It is possible to force the power cable connector into the cable holder incorrectly. If the connector is reversed, the unit will not work. Examine the contacts on the back of the unit to ensure there is no corrosion. Finally, ensure the unit is firmly seated on the mount. The electrical contacts are not made until the unit is fully seated.

Ensure the metal cable retainer is properly installed in the mount. If not, the power connected may push out when the unit is put on the mount.

2. *There is no transducer detected.*

Most Humminbird fishfinders have the ability to detect and identify that a transducer is connected. If at power up, a message indicates “transducer not connected,” only simulator operation is possible. First, ensure that an appropriate transducer connector is positioned correctly in the connector holder, and that the unit is fully seated on the mount. Your Humminbird fishfinder will work only with an appropriate transducer; check the accessory guide for compatibility.

MAINTENANCE AND WARRANTY

TROUBLESHOOTING

Second, inspect the transducer cable from end to end for breaks, kinks, or cuts in the outer casing of the cable. Also ensure the transducer is fully submerged in water. If the transducer is connected to the unit through a switch, temporarily connect it directly to the unit and try again. If none of these items identifies an obvious problem, the transducer itself is probably the problem. Be sure to include the transducer if returning the unit for repair.

3. There is no bottom reading visible on the display.

There are a number of possible causes for this condition. If the loss of bottom information occurs only at high boat speeds, the transducer needs adjusting. If the digital depth readout is working but there is no bottom visible on-screen, it is possible the depth range has been adjusted manually to a range lower than what is needed to display the bottom. Also, in very deep water, it may be necessary to manually increase the sensitivity setting to maintain a graphic depiction of the bottom.

If you are using a transducer switch to connect two transducers to the unit, ensure the switch is in the correct position to connect a transducer that is in water. (If a trolling motor transducer is selected and the trolling motor is out of water, no sonar information appears.)

If none of the above solve the problem, inspect the transducer cable from end to end for breaks, kinks, or cuts in the outer casing of the cable. If the transducer is connected to the unit through a switch, temporarily connect it directly to the unit and try again. If none of these items identifies an obvious problem, the transducer itself may be the problem. Be sure to include the transducer if returning the unit for repair.

4. When in very shallow water, I get gaps in the bottom reading and inconsistent digital depth indication.

Your Humminbird fishfinder will work reliably in water 2' (.6m) or deeper. The depth is measured from the transducer, not necessarily from the surface.

MAINTENANCE AND WARRANTY

TROUBLESHOOTING

5. *The unit comes on before I press POWER, and won't turn off.*

Check the transducer cable. If the outer jacket of the cable has been cut and the cable is in contact with bare metal, you need to repair the cut with electrical tape. If there is no problem with the cable, disconnect the transducer from the unit and see if the problem is corrected, to confirm the source of the problem.

6. *I get gaps in the reading at high speeds.*

Your transducer needs adjusting. If the transducer is transom-mounted, there are two adjustments available to you - height and running angle. Make small adjustments and run the boat at high speeds to determine the effect. It may take several tries to optimize high speed operation. This can also be a result of air or turbulence in the transducer location caused by rivets, ribs, etc.

7. *My unit loses power at high speeds.*

Most Humminbird fishfinders have over-voltage protection that turns the unit off when input voltage exceeds 20 VDC. Some outboard motors do not effectively regulate the power output of the engine's alternator and can produce voltage in excess of 20 volts when running at high RPMs. Your fishfinder displays input voltage in the Diagnostic screen. Use this readout to determine if the voltage exceeds 20 VDC.

8. *The screen begins to fadeout. Images are not as sharp as normal.*

Check the input voltage using Diagnostic. The fishfinder will not operate on input voltages below 10 VDC.

9. *The display shows many black dots at high speeds and high sensitivity settings.*

You are seeing noise or interference caused by one of several sources. Noise can be caused by other electronic devices. Turn off any nearby electronics and see if the problem goes away. Noise can also be caused by the engine. If engine noise is causing the interference, the problem will intensify at higher RPMs. Increase the engine speed with the boat stationary to isolate this cause. Propeller cavitation can appear as noise on-screen. If the transducer is mounted too close to the propeller, the turbulence generated can interfere with the sonar signal. Ensure that the transducer is mounted at least 15" (38cm) from the prop.

MAINTENANCE AND WARRANTY

WARRANTY

HUMMINBIRD ONE YEAR FULL WARRANTY

First year repairs (from original date of purchase) on your Humminbird fishfinder are absolutely free. This does not include physical damage to the unit or its accessory items. Any modification or attempt to repair the original equipment or accessories by unauthorized individuals will void the warranty. Return the warranty registration card and retain your bill of sale for warranty verification. Accessories not manufactured under the Humminbird trade name are not covered by our warranty. **The customer is responsible for shipping charges to Humminbird.** Humminbird will provide ground UPS or Parcel Post shipping back to the customer free of charge. This warranty applies to the original purchaser only.

This warranty is in lieu of all other warranties expressed or implied and no representatives or persons are authorized to provide for any other liability in connection with the sale of our products. Humminbird reserves the right to perform modifications or improvement on its products without incurring the obligation to install the changes on units previously manufactured, sold, delivered, or serviced.

THIS IS A FULL WARRANTY AS DEFINED BY THE FEDERAL WARRANTY ACT EFFECTIVE JULY 4 1975.

MAINTENANCE AND WARRANTY

SERVICE POLICY

SERVICE POLICY

This Service Policy is valid in the United States only. This applies to Humminbird units returned to our factory in Eufaula, Alabama, and is subject to change without notice.

All repair work is performed by factory-trained technicians to meet exacting factory specifications. Factory serviced units go through the same rigorous testing and quality control inspection as new production units.

Even though you'll probably never need to take advantage of our incredible service guarantee, it's good to know that we back our unit this well. We do it because you deserve the best. We will make every effort to repair your unit within three working days from the receipt of your unit. This does not include shipping time to and from our factory. Units received on Friday are usually shipped by Wednesday, units received Monday are usually shipped by Thursday, etc.

We reserve the right to deem any product unserviceable when replacement parts are no longer reasonably available or impossible to obtain.

After the original warranty period, a standard flat rate service charge will be assessed for each repair (physical damage and missing parts are not included). Please call our Customer Support Department to verify the service charge for your unit.

The standard service charge includes UPS or Parcel Post freight only. If charges are not prepaid, the unit will be returned COD. If you are experiencing problems related to bottom or depth readings please send your transducer along with your unit when sending for repair.

MAINTENANCE AND WARRANTY

CUSTOMER SUPPORT

CUSTOMER SUPPORT

If you have any questions, call our
Humminbird Customer Support Hotline: **1-334-687-0503**

Throughout the U.S. and Canada, hours are Monday-Friday, 8:00 a.m. to 5:00 p.m.
Central time.

If after reading "Troubleshooting" you determine your unit needs factory service, please
attach a description of the problem and send it with the unit to the address below.

If you are including a check please attach it to the unit.

**Humminbird
Service Department
Three Humminbird Lane
Eufaula, AL 36027
USA**