

# Humminbird® HDR 610 Installation and Operations Manual

531440-1\_B

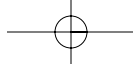



## THANK YOU!

Thank you for choosing Humminbird®, America's #1 name in fishfinders. Humminbird® has built its reputation by designing and manufacturing top-quality, thoroughly reliable marine equipment.

Your Humminbird® is designed for trouble-free use in even the harshest marine environment. In the unlikely event that your Humminbird® does require repairs, we offer an exclusive Service Policy - free of charge during the first year after purchase, and available at a reasonable rate after the one-year period. For complete details, see the Warranty section included in this manual.

Contact our Customer Resource Center at either 1-800-633-1468 or visit our website at [www.humminbird.com](http://www.humminbird.com).

## TABLE OF CONTENTS

<b>How Sonar Works</b>	<b>4</b>
<b>Installation Overview</b>	<b>5</b>
Installing the HDR 610 .....	6
1. Locating the HDR 610 Mounting Position .....	7
2. Cutting the Mounting Hole .....	7
3. Customizing and Assembling the HDR 610.....	7
4. Installing the HDR 610 .....	9
5. Installing the Buzzer .....	9
6. Connecting the Transducer Cable .....	10
7. Connecting to the Power Supply .....	10
<b>Transducer Installation</b>	<b>11</b>
<b>Transom Transducer Installation</b> .....	11
1. Locating the Transducer Mounting Position .....	11
2. Mounting the Bracket .....	12
3. Transducer Assembly .....	12
4. Mounting the Transducer Assembly to the Transom .....	13
5. Running Position Adjustment .....	13
6. Routing the Transducer Cable .....	14
7. Final Testing .....	15
<b>Inside the Hull Transducer Installation</b> .....	15
1. Locating the Transducer Mounting Position .....	16
2. Trial Installation .....	16
3. Routing the Cable .....	17
4. Permanently Mounting the Transducer .....	17
<b>Trolling Motor Transducer Installation</b> .....	18
<b>Trolling Motor Transducer Options</b> .....	18
<b>Test and Finish the Installation</b>	<b>19</b>
<b>Inside the Hull Mounting, Puck Transducers Only</b>	<b>20</b>
1. Locating the Transducer Mounting Position .....	20
2. Trial Installation .....	20
3. Routing the Cable .....	21
4. Permanently Mounting the Transducer .....	21
<b>Operating the HDR 610</b>	<b>23</b>
What's on the Display .....	23
Key Functions .....	23
Shallow Alarm .....	24
Deep Alarm .....	24
Units .....	25
Keel Offset .....	26

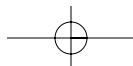

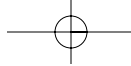

<b>Maintenance</b>	<b>28</b>
HDR 610 Maintenance .....	28
Transducer Maintenance.....	28
<b>Troubleshooting</b>	<b>28</b>
HDR 610 Doesn't Power Up.....	29
No Bottom Reading on the Display .....	29
No Continuous Depth Display in Very Shallow Water.....	29
Screen Fades, Images are Not Sharp .....	29
Bottom Reading Disappears During a Hard Turn.....	29
<b>1-Year Limited Warranty</b>	<b>30</b>
<b>Humminbird® Service Policy</b>	<b>30</b>
Returning Your Unit for Service.....	31
<b>Specifications</b>	<b>32</b>
<b>Contact Humminbird®</b>	<b>33</b>
<b>Transom Mount Transducer Mounting Template</b>	<b>34</b>

## HOW SONAR WORKS

Sonar technology is based on sound waves. The HDR 610 Digital Depth Gauge uses sonar to determine depth directly below the transducer. Your HDR 610 Digital Depth Gauge consists of two components: the HDR 610 sonar unit and the transducer. The sonar unit contains the transmitter and receiver, as well as the user controls and display. The transducer is mounted beneath the water surface and converts electrical energy from the transmitter into mechanical pulses or sound waves. The transducer also receives the reflected sound waves and converts them back into electrical signals for display on the sonar unit.

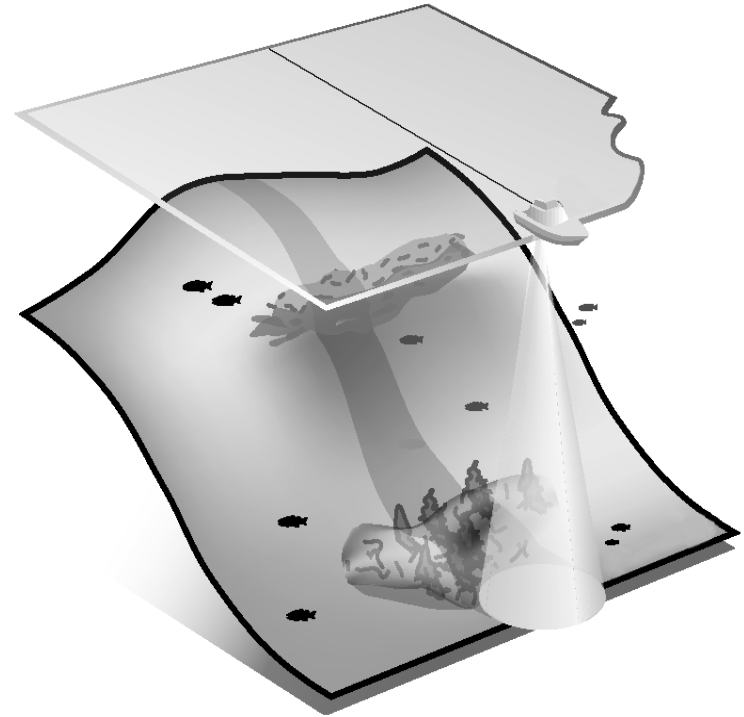

Sonar is very fast. A sound wave can travel from the surface to a depth of 240 ft (70 m) and back again in less than 1/4 of a second. It is unlikely that your boat can "outrun" this sonar signal.

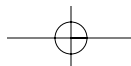

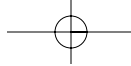

## INSTALLATION OVERVIEW

Before you start installation, we encourage you to read these instructions carefully in order to get the full benefit from your HDR 610 Digital Depth Gauge. You will install your HDR 610 depthsounder first, then your transducer. When you are done with both of these installation tasks, you should perform a final installation test before operating your HDR 610.

Please make sure that the following parts are included for your depthsounder:

- HDR 610 depthsounder
- "U" bracket and mounting hardware
- 2 cable ties.

Also, please make sure the following parts are included for your transducer:

- Transom mount or Puck transducer with 20' of cable
- Transducer mounting hardware kit.

In addition to the hardware supplied, you will need the following for installation and operation:

- Powered hand drill and various drill bits, including a 2 1/8" hole saw, if your boat does not have an existing gauge hole
- Phillips-head and flat-head screwdrivers
- Ruler or measuring tape
- Pen or pencil
- 12 Volt power source (your boat's battery)
- Marine-grade silicone sealant (for sealing drilled holes)
- Two-part, slow-cure epoxy (for inside-the-hull transducer installation only).

**NOTE:** If you are wiring directly to the boat's battery, you will also need a 1 Amp fuse and a fuse holder.

## INSTALLING THE HDR 610

Before installing the HDR 610, make sure you have the following parts:

- HDR 610 depthsounder
- "U" bracket and mounting hardware
- 2 cable ties.

Perform the following high-level steps by following the instructions in each numbered section to install the HDR 610 depthsounder:

1. Locating the HDR 610 mounting position
2. Cutting the mounting hole
3. Customizing and assembling the HDR 610
4. Installing the HDR 610
5. Installing the buzzer
6. Connecting the transducer cable
7. Connecting to the power supply.

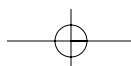

## 1. Locating the HDR 610 Mounting Position

You must select an appropriate mounting location for the HDR 610. Consider different positions on the console or deck of the boat. Remember that the cables for the transducer and power must reach the mounting location. Extension cables are available.

The mounting surface should be visible to the boat operator and adequately supported to protect the HDR 610 from excessive wave shock and vibration. Allow at least 2" clearance at the back, sides, and top of the unit for connection, air flow, and ease of installation and removal.

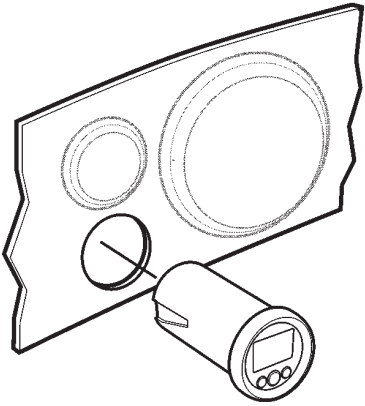

## 2. Cutting the Mounting Hole

Once you have selected your mounting location, perform the following steps:

1. Mark the desired mounting location, then drill a pilot hole.
2. Drill a 2 1/8" diameter hole using a hole saw and hand drill. This is a standard hole saw readily available for rental or purchase. If you prefer, any marine service shop can perform this task.

## 3. Customizing and Assembling the HDR 610

Your HDR 610 comes with both black and white bezels, and both black and white overlays. You must select one color for the bezel, and another color for the overlay, and perform the following assembly steps:

1. Peel off the protective backing from the overlay, being careful not to let the adhesive touch anything prematurely.

**WARNING:** In order to provide a lasting, waterproof bond, the overlay adhesive is extremely sticky, and therefore you will NOT be able to re-position it once you have stuck it onto the face of the HDR 610.

2. Carefully line up the notch on the bottom of the overlay with the tab at the bottom of the face of the HDR 610, then press the overlay into place so that all buttons and the display show through.
3. The bezel is keyed to fit only one way onto the front of the HDR 610. There are two opposing sets of tabs on the inside of the bezel: two wide tabs, and two tabs with slots in them. Find the tab that has the asymmetrical slots (refer to the illustration) and push the bezel onto the front of the HDR 610 according to the illustration.

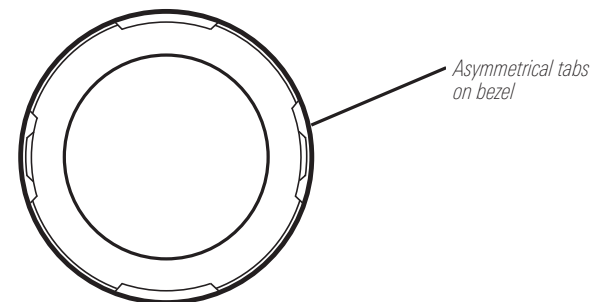
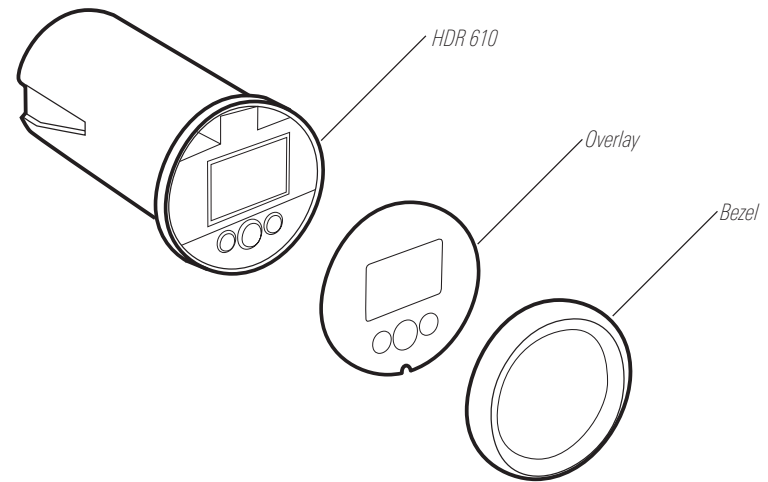

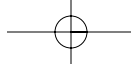

## 4. Installing the HDR 610

Once you have your mounting hole cut, perform the following steps:

1. Insert the HDR 610 from the front of the panel.
2. Install the "U" bracket and wingnut from the rear of the panel, and make sure that the face of the HDR 610 is oriented correctly, so that the top of the unit is at the top of the hole.

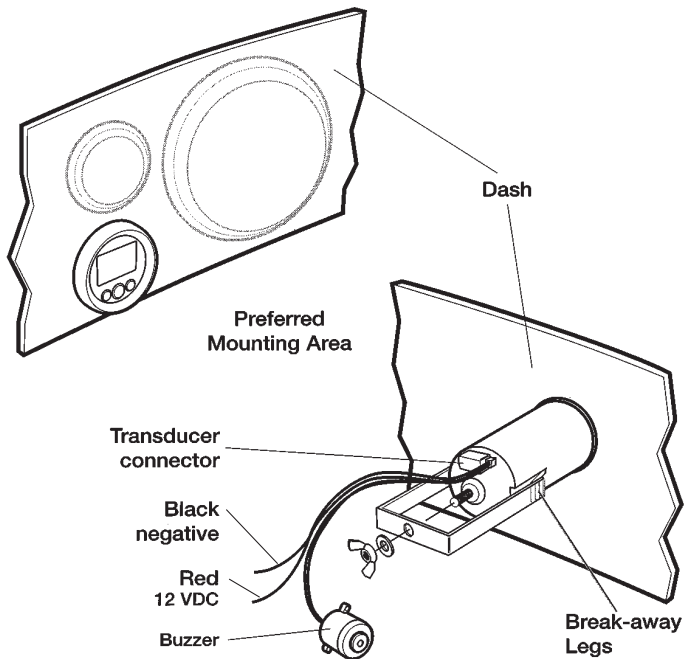

**NOTE:** If the panel into which you are mounting the unit is greater than 1/4" thick, the "U" bracket may appear too long. You may modify the "U" bracket by using pliers to break the legs of the bracket at the score lines. Shorten the bracket in gradual stages to avoid making it too short.

3. Tighten the wingnut to secure the installation.

## 5. Installing the Buzzer

Once the unit is mounted in the dash, secure the buzzer either to the metal bracket or to a nearby wire bundle using the cable ties included.

## 6. Connecting the Transducer Cable

Connect the transducer cable to the transducer connector on the HDR 610.

**NOTE:** The connector is keyed to prevent reverse installation, so be careful not to force the plug into the connector the wrong way.

## 7. Connecting to the Power Supply

Use the following information to connect your HDR 610 to an appropriate power supply:

- If your boat has an electrical system, there is probably a fuse panel in the console area that can be used to attach the HDR 610 power cable.
- If a fuse terminal is available, use crimp-on type electrical connectors (not included) that match the terminal on the fuse panel, and attach the black wire to ground, and the red wire to 12 VDC power. You must use a 1-Amp fuse in the connection.
- 36" of power cable is included; you may shorten or lengthen this cable using 18-gauge, multi-strand copper wire.

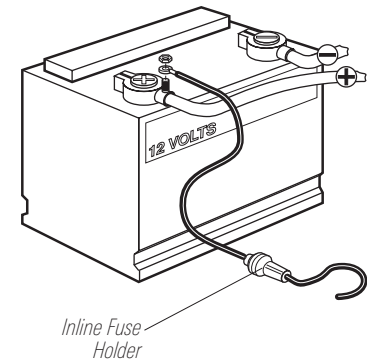
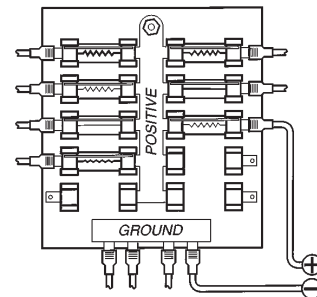

**CAUTION:** Some boats have 24 or 36 Volt electrical systems. Make sure that your HDR 610 is connected to a 12 VDC power supply. Use a voltage conditioner for variable inputs.

- If you must wire the HDR 610 directly to a battery, make sure that you install an in-line fuse holder and a 1-Amp fuse (not included) for the protection of the unit. Humminbird® is not responsible for over-voltage or over-current failures.

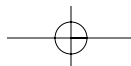

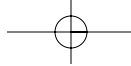

## TRANSDUCER INSTALLATION

If you have a transom mount transducer you can mount it on the transom (preferred), in the hull, or you can purchase the trolling motor adapter and mount it on your trolling motor. If you have a puck transducer then you can ONLY mount it in the hull; there is a separate inside the hull mounting section for puck transducers. Find the correct section for your transducer installation type.

The included transducer is designed for transom mounting on the boat (directly exposed to the water). On fiberglass hull boats, this same transducer can be bonded to the inside of the hull. When mounted inside the hull, the sonar signal actually passes through the hull of the boat. One of these two mounting techniques will produce acceptable results on most boats. There are, however, several situations that may demand a different type of transducer. Inboard boats, wood or metal hulls, and sailboats often have unique transducer mounting requirements.

## TRANSOM TRANSDUCER INSTALLATION

### 1. Locating the Transducer Mounting Position

**NOTE:** If transom mounting is not possible because of a stepped hull or cavitation noise, and you have a single layer fiberglass hull, in-hull installation is an option. See *Inside the Hull Transducer Installation* for more information.

First, determine the best location on the transom to install the transducer. Consider the following to find the best location:

- It is very important to locate the transducer in an area which is relatively free of turbulent water. As a boat moves through the water, turbulence is generated by the weight of the boat, and the thrust of the propeller(s) - either clockwise or counter-clockwise. This turbulent water is normally confined to areas immediately aft of ribs, strakes or rows of rivets on the bottom of the boat, and in the immediate area of the propeller(s). Clockwise propellers create more turbulence on the port side. On outboard or inboard/outboard boats, it is best to locate the transducer at least 15" (380 mm) to the side of the propeller(s).
- The best way to locate turbulence-free water is to view the transom while the boat is moving. This method is recommended if maximum high-speed operation is a high priority. If this is not possible, select a location on the transom where the hull forward of this location is smooth, flat and free of protrusions or ribs.
- The hydrodynamic shape of your transducer allows it to point straight down without deadrise adjustment.

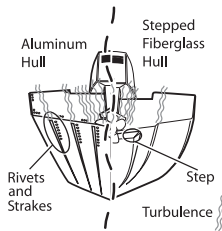

- On boats with stepped hulls, it may be possible to mount the transducer on the step. Do not mount the transducer on the transom behind a step to avoid popping the transducer out of the water at higher speeds; the transducer must remain in the water for the depthsounder to maintain the sonar signal.
- If the transom is behind the propeller(s), it may be impossible to find an area clear from turbulence, and a different mounting technique or transducer type should be considered (see *Inside the Hull Transducer Installation*).

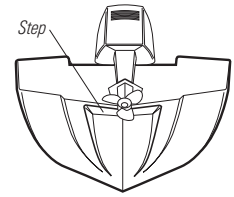

### 2. Mounting the Bracket

- Remove the transducer mounting template from the end of this manual.

**NOTE:** Please make sure that you use the correct drill holes for the hull composition of your boat.

- Hold the template on the transom of the boat in the location where the transducer will be installed. Align the template vertically, matching the lower edge of the transom with the bottom corner of the template. If your propeller moves clockwise as the boat moves forward, mount the transducer on the starboard side, and use the bottom left corner of the template. If your propeller moves counter-clockwise as the boat moves forward, mount the transducer on the port side, and use the bottom right corner of the template.
- Using a pencil or punch, mark the two mounting holes (shown on the template for your type of hull) on the transom. Do not mark or drill any other holes at this time.
- Using a 9/64" (3.5 mm) bit, drill the two holes to a depth of approximately 1" (25 mm).

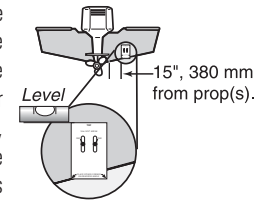

### 3. Transducer Assembly

**NOTE:** The transducer assembly referred to in this step consists of the transducer connected to either the Single Piece or the Two Piece Kick-up mounting bracket.

- Attach the Single Piece mounting bracket or the Two Piece Kick-up pivot to the transducer body, using the 1/4" - 20 x 1 1/4" Phillips head pivot bolt, the nyloc nut, and the two toothed lock washers.

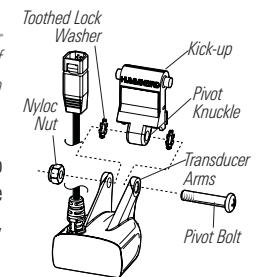
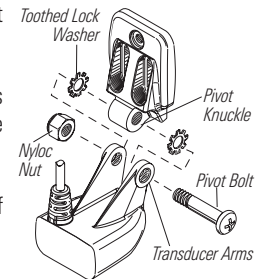

**NOTE:** The toothed lock washers must be positioned between the transducer arms and the pivot knuckle regardless of mounting bracket type.

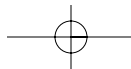

- Using a Phillips screwdriver and a 7/16" wrench, loosely tighten the pivot bolt. Do not completely tighten the assembly at this time, so the pivot angle can be adjusted later.
- Only if you have a Kick-up transducer mounting assembly, insert the pivot/transducer assembly into the mounting bracket.
- Do not snap the assembly closed.**

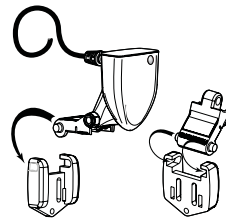
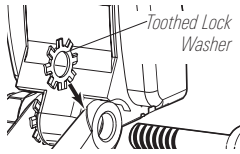

Initial Bracket Mounting

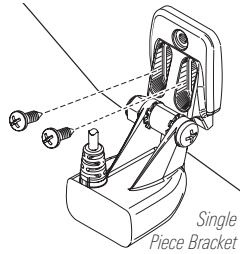

Single Piece Bracket

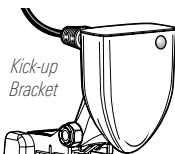

Kick-up Bracket

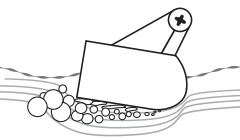
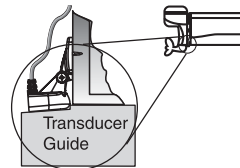

Cavitation that will cause erratic sonar readings

#### 4. Mounting the Transducer Assembly to the Transom

- Apply marine-grade silicone sealant to the mounting holes drilled into the transom.
- Align the transducer assembly with the drilled holes in the transom.
- Using the appropriate tool for your mounting hardware, attach the transducer assembly to the boat transom as shown, using #8 x 5/8" (16 mm) wood screws. Do not fully tighten the mounting screws in order to vertically adjust the transducer. If you have a Two Piece Kick-up transducer mounting assembly, snap the pivot down into place.

#### 5. Running Position Adjustment

The transducer mounting bracket allows height and tilt adjustment, while the pivot bolt allows angular adjustment. These adjustments will help reduce cavitation. Initially, adjust the transducer as described in the following paragraphs. Further adjustment may be necessary to refine the installation after high-speed testing.

- First, adjust the pivot angle of the transducer body, so its length is parallel with the length of the hull of the boat. Then, using the angle portion of the mounting template, pivot the transducer down so that it matches the template angle as shown on the template itself.
- Fully tighten the pivot bolt, using a Phillips head screwdriver and a wrench. It may be necessary to re-tighten the pivot bolt after initial use as the plastic may still be conforming to the pressure from the lock washers.

- Before removing the template, adjust the height of the assembly so the face of the transducer touches the face of the template. Mark the position of the mounting bracket on the transom with a pencil.

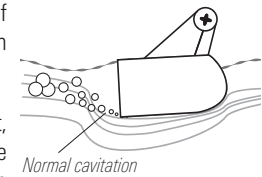

Normal cavitation

- If you are using the Two Piece Kick-up mounting bracket, force the pivot to the Up position to gain access to the mounting screws. Make sure that the transducer location has not changed, then hand tighten the two mounting screws. Snap the pivot back down.
- If you are using the Single Piece mounting bracket, make sure that the transducer location has not changed, then hand tighten the two mounting screws.
- Confirm that the pivot angle has not changed.**

#### 6. Routing the Transducer Cable

There are several ways to route the transducer cable to the area where the depthsounder will be installed. The most common procedure routes the cable through the transom into the boat.

**NOTE:** Your boat may have a pre-existing wiring channel or conduit that you can use for the transducer cable.

- Unplug the other end of the transducer cable from the depthsounder. Make sure that the cable is long enough to accommodate the planned route by running the cable over the transom.

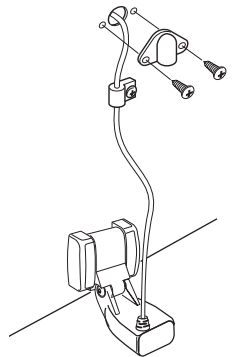

**CAUTION!** Do not cut or shorten the transducer cable, and try not to damage the cable insulation. Route the cable as far as possible from any VHF radio antenna cables or tachometer cables to reduce the possibility of interference. If the cable is too short, extension cables are available to extend the transducer cable up to a total of 50' (15 m). For assistance, contact the Customer Resource Center at [www.humminbird.com](http://www.humminbird.com) or call 1-800-633-1468 for more information.

**NOTE:** The Two Piece Kick-up transducers can pivot up to 90 degrees in the bracket. Allow enough slack in the cable for this movement. It is best to route the cable to the side of the transducer so the cable will not be damaged by the transducer during movement.

- If you are routing the cable over the transom of the boat, secure the cable by attaching the cable clamp to the transom, drilling 9/64" dia. holes for #8 x 5/8" (16 mm) wood screw(s), then skip directly to step 5.
- If you will be routing the cable through a hole in the transom, drill a 5/8" diameter (16 mm) hole above the waterline. Route the cable through this hole, then fill the hole with marine-grade silicone sealant and proceed to the next step immediately.



3. Place the escutcheon plate over the cable hole and use it as a guide to mark the two escutcheon plate mounting holes. Remove the plate, drill two 9/64" dia. (3.5 mm) x 5/8" deep (16 mm) holes, then fill both holes with marine-grade silicone sealant. Place the escutcheon plate over the cable hole and attach with two #8 x 5/8" (16 mm) wood screws.
4. Route and secure the cable by attaching the cable clamp to the transom; drill one 9/64" dia. (3.5 mm) x 5/8" deep (16 mm) hole, then fill hole with marine-grade silicone sealant, then attach the cable clamp using a #8 x 5/8" (16 mm) screw.
5. Plug the other end of the transducer cable back into the depthsounder connection holder.

## 7. Final Testing

After transom transducer installation, please perform the final testing and then finalize the installation (see *Test and Finish the Installation*).

## INSIDE THE HULL TRANSDUCER INSTALLATION

**NOTE:** If you have a puck transducer, please use the procedure found in the *Inside the Hull Mounting, Puck Transducers Only* section instead.

In-hull mounting generally produces good results in single-thickness fiberglass-hulled boats. Humminbird® cannot guarantee depth performance when transmitting and receiving through the hull of the boat, since some signal loss occurs. The amount of loss depends on hull construction and thickness, as well as the installation position and process.

This installation requires slow-cure two-part epoxy. Do not use silicone or any other soft adhesive to install the transducer, as this material reduces the sensitivity of the unit. Do not use five-minute epoxy, as it has a tendency to cure before all the air bubbles can be purged, thus reducing signal strength.

**NOTE:** In-hull mounting requires an installed and operational depthsounder.

Transducer Mounted Inside the Hull

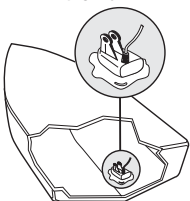

Preferred Mounting Area

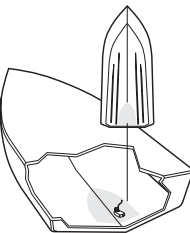

## 1. Locating the Transducer Mounting Position

Decide where to install the transducer on the inside of the hull. Consider the following to find the best location:

- Observe the outside of the boat hull to find the areas that are mostly free from turbulent water. Avoid ribs, strakes and other protrusions, as these create turbulence.
- As a general rule, the faster the boat can travel, the further aft and closer to the centerline of the hull the transducer has to be located in order to remain in contact with the water at high speeds.

## 2. Trial Installation

You will not be able to adjust the mounting after an inside the hull transducer is installed. It is best, therefore, to perform a trial installation first that includes running the boat at various speeds, in order to determine the best mounting area before permanently mounting the transducer.

1. Plug the transducer into the depthsounder, then power up the depthsounder. When the depthsounder detects a functioning transducer, it will automatically enter Normal operating mode.
2. View the sonar signal at its best by holding the transducer over the side, immersed in the water, so that it is pointing straight down over a known flat bottom. Use the display to benchmark against the sonar signal that will be detected once the transducer is placed in the hull.
3. Place the transducer body face down at the identified mounting location inside the hull, with the pointed end towards the bow.
4. Fill the hull with enough water to submerge the transducer body. Use a sand-filled bag or other heavy object to hold the transducer in position. The transducer cannot transmit through air, and the water purges any air from between the transducer and the hull, and fills any voids in the coarse fiberglass surface.
5. View the sonar signal on the display and compare against what was observed in Step 2, making sure that the boat is in the same location as it was during your observations in Step 2. If the results are comparable, move on to Step 6. Otherwise, locate a new position in the hull and repeat Steps 3 through 5.
6. Run the boat at various speeds and water depths while observing the screen on the depthsounder. If depth performance is required, test the transducer in water at the desired depth. If the performance is acceptable, move on to Step 7. If the performance is not acceptable, repeat Steps 3 through 6.
7. Once you have determined the best mounting location using the above steps, mark the position of the transducer.

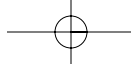

### 3. Routing the Cable

- Once the mounting location is determined and you have marked the position of the transducer, route the cable from the transducer to the depthsounder.

**CAUTION!** Do not cut or shorten the transducer cable, and try not to damage the cable insulation. Route the cable as far as possible from any VHF radio antenna cables or tachometer cables to reduce the possibility of interference. If the cable is too short, extension cables are available to extend the transducer cable up to a total of 50' (15 m). For assistance, contact the Customer Resource Center at [www.humminbird.com](http://www.humminbird.com) or call 1-800-633-1468 for more information.

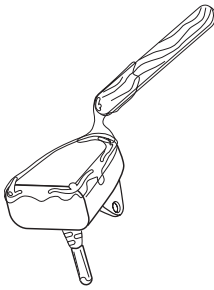

### 4. Permanently Mounting the Transducer

**NOTE:** Once permanently mounted, you will not be able to make further adjustments to the transducer.

- Make sure the position of the transducer is marked.
- Remove the water from inside the hull and thoroughly dry the mounting surface. If the surface is excessively rough, it may be necessary to sand the area to provide a smooth mounting surface.
- Mix an ample quantity of two-part slow cure epoxy slowly and thoroughly. Avoid trapping air bubbles.
- Coat the face of the transducer and the inside of the hull with epoxy.
- Press the transducer into place with a slight twisting motion to purge any trapped air from underneath, keeping the pointed end of the transducer body pointed forward, towards the bow.

**NOTE:** Proper operation requires the pointed end of the transducer body to face towards the bow.

- Weight the transducer so that it will not move while the epoxy is curing.

**NOTE:** When the epoxy cures, no water is necessary inside the hull.

- If you unplugged the transducer cable at the beginning of this procedure, plug it back into the depthsounder.

**NOTE:** Neither water, spilled gasoline, nor oil will affect the performance of the transducer.

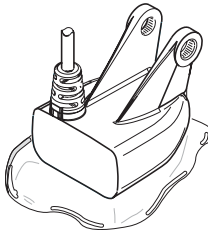

### TROLLING MOTOR TRANSDUCER INSTALLATION

Several styles of the transducer are compatible with trolling motor mounting. If you have a trolling motor bracket, refer to the separate installation instructions that are included with the bracket.

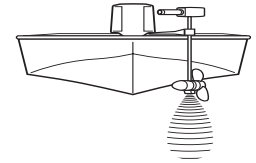

#### Trolling Motor Transducer Options

If you don't have a trolling motor transducer, there are several options:

- You may purchase a Trolling Motor Adapter kit that will allow you to mount the transducer on the trolling motor.
- You may also exchange your NEW and UNASSEMBLED transducer (with mounting hardware included) for a trolling motor transducer.

There are also several transducer switches available that support the following configurations:

- Two depthsounders with one transducer or two transducers with one depthsounder.

**NOTE:** Call the Humminbird® Customer Resource Center at 1-800-633-1468 for details and pricing, or visit [www.humminbird.com](http://www.humminbird.com) for more information.

### TEST AND FINISH THE INSTALLATION

After installing your HDR 610, transducer, and cables, you should test the installation. Testing should be performed on the water, since that is the only way to evaluate the performance of your transducer.

- When the boat ignition is turned on, the HDR 610 will perform a self test, and then begin transmitting. It will automatically display the digital depth.

**NOTE:** If the HDR 610 is wired to a different switch than the ignition switch, turn that switch on instead.

- Increase your boat speed to ensure that you get a continuous bottom reading as the boat moves.

**CAUTION:** Your HDR 610 and transducer are designed to operate at up to 75 mph, but use caution when operating any boat at high speed.

- If the HDR 610 performs well at idle or slow speeds, but the display is not continuous at higher speeds, the transducer is not installed correctly. Air bubbles or turbulence from the boat hull are passing across the transducer face, and blocking the transmitted signal. If you have the correct angle set on the transducer, yet lose a bottom reading at high speed, adjust the transducer to a lower depth in the water. If you reach the top of the screw slots and continue to lack high speed performance, increase the angle of the transducer by lowering the back of the transducer in increments of 1/8" (4 mm).

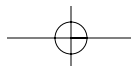

**NOTE:** It is often necessary to make several incremental transducer adjustments before optimum high speed performance is achieved.

- Once you have obtained successful test results, you must install the third mounting screw for transom mount transducer installations.

**IMPORTANT:** For Transom Mount transducer installations, install the third mounting screw after the final transducer adjustments. Hand tighten only.

- If you have a Single Piece mounting bracket, use the bracket as a guide and drill the third hole to a depth of approximately 1" using a 9/64" (3.5 mm) drill bit, apply marine-grade silicone sealant to the hole, and lock down the transducer settings by screwing in the third #8 x 5/8" (16 mm) wood screw. Hand-tighten only.
- If you have a Two Piece Kick-up mounting bracket, mark the transducer bracket location on the transom with a pencil, then pop up the bracket to reveal the mounting screws. Find the third mounting hole in the vertical center of the bracket. Make sure that the bracket location is in between the same place and drill the third hole to a depth of approximately 1" using a 9/64" (3.5 mm) drill bit. Fill the mounting hole with marine-grade silicone, then install the third #8 x 5/8" (16 mm) wood screw before snapping the transducer bracket closed. Hand-tighten only.

Installing the Third Mounting Screw

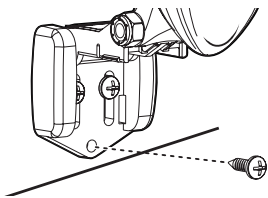

- Your depthsounder is now ready for operation.

## INSIDE THE HULL MOUNTING, PUCK TRANSDUCERS ONLY

Perform these particular inside the hull instructions only if you have a puck transducer. Inside the hull mounting of the transducer generally produces good results in single thickness fiberglass hulled boats. Humminbird® cannot guarantee depth performance when transmitting and receiving through the hull of the boat, since some signal loss will occur. The amount of loss depends on hull construction and thickness, and the installation.

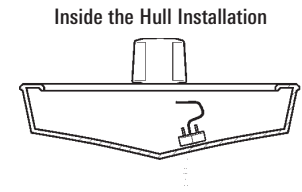

This type of installation requires the use of a slow-cure two-part epoxy (included with your transducer). Do not use silicone or any other soft adhesive material to install the transducer, as this material will reduce the sensitivity of the unit. Do not use five-minute epoxy, as it has a tendency to cure before all the air bubbles can be purged, thus reducing signal strength.

### 1. Locating the Transducer Mounting Position

Decide where to install the transducer on the inside of the hull. Consider the following to find the best location:

- Observe the outside of the boat hull to find the areas that are mostly free from turbulent water. Avoid ribs, strakes and other protrusions, as these create turbulence.
- As a general rule, the faster the boat can travel, the further aft and closer to the centerline of the hull the transducer has to be located in order to remain in contact with the water at high speeds.

### 2. Trial Installation

You will not be able to adjust the mounting after an inside the hull transducer is installed. It is best, therefore, to perform a trial installation first that includes running the boat at various speeds, in order to determine the best mounting area before permanently mounting the transducer.

- Plug the transducer into the depthsounder, then power up the depthsounder. When the depthsounder detects a functioning transducer, it will automatically enter Normal operating mode.
- View the sonar signal at its best by holding the transducer over the side, immersed in the water, so that it is pointing straight down over a known flat bottom. Use the display to benchmark against the sonar signal that will be detected once the transducer is placed in the hull.

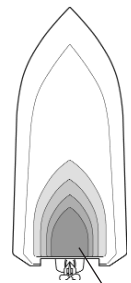

Preferred Mounting Area

3. Place the transducer body face down on the inside of the hull in the area you have selected.
4. Fill the hull with enough water to submerge the transducer body. Use a sand-filled bag or other heavy object to hold the transducer in position. The transducer cannot transmit through air, and the water purges any air from between the transducer and the hull, and fills any voids in the coarse fiberglass surface.
5. View the sonar signal on the display and compare against what was observed in Step 2, making sure that the boat is in the same location as it was during your observations in Step 2. If the results are comparable, move on to Step 6. Otherwise, locate a new position in the hull and repeat Steps 3 through 5.
6. Run the boat at various speeds and water depths while observing the screen on the depthsounder. If depth performance is required, test the transducer in water at the desired depth. If the performance is acceptable, move on to Step 7. If the performance is not acceptable, repeat Steps 3 through 6.
7. Once you have determined the best mounting location using the above steps, mark the position of the transducer.

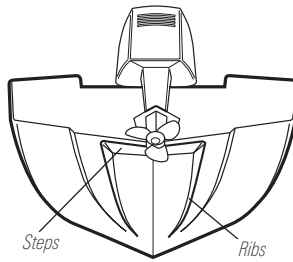

3. Mix an ample quantity of two-part slow cure epoxy slowly and thoroughly. Avoid trapping air bubbles.
4. Coat the face of the transducer and the inside of the hull with epoxy.
5. Press the transducer into place with a slight twisting motion to purge any trapped air from underneath.

**NOTE:** Puck or round, circular-bottomed transducers have no directional bias, and therefore orientation of these types of transducers is not as important.

6. Weight the transducer so that it will not move while the epoxy is curing.

**NOTE:** When the epoxy cures, no water is necessary inside the hull.

7. If you unplugged the transducer cable at the beginning of this procedure, plug it back into the depthsounder.

**NOTE:** Neither water, spilled gasoline, nor oil will affect the performance of the transducer.

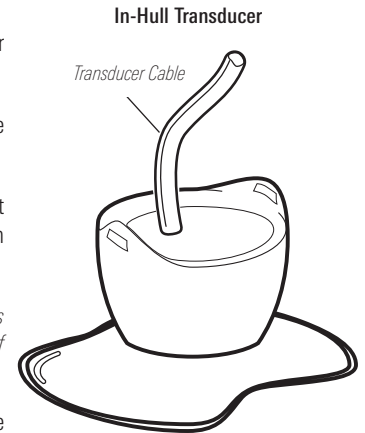

### 3. Routing the Cable

1. Once the mounting location is determined and you have marked the position of the transducer, route the cable from the transducer to the depthsounder.

**CAUTION!** Do not cut or shorten the transducer cable, and try not to damage the cable insulation. Route the cable as far as possible from any VHF radio antenna cables or tachometer cables to reduce the possibility of interference. If the cable is too short, extension cables are available to extend the transducer cable up to a total of 50' (15 m). For assistance, contact the Customer Resource Center at [www.humminbird.com](http://www.humminbird.com) or call 1-800-633-1468 for more information.

### 4. Permanently Mounting the Transducer

**NOTE:** Once permanently mounted, you will not be able to make further adjustments to the transducer.

1. Make sure the position of the transducer is marked.
2. Remove the water from inside the hull and thoroughly dry the mounting surface. If the surface is excessively rough, it may be necessary to sand the area to provide a smooth mounting surface.

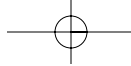

## OPERATING THE HDR 610

Your HDR 610 Digital Depth Gauge sends a sound wave signal and determines distance by measuring the time between the transmission of the sound wave and when the sound wave is reflected off of an object. As your HDR 610 transducer receives sonar signals, it converts them to a digital depth that is shown on the HDR 610 display. The depth reading is continuously updated as you travel across the water. The liquid crystal display (LCD) offers sharp viewing, even in bright, direct sunlight, and is continuously lit for nighttime operation.

**NOTE:** Actual depth capability depends on such factors as bottom hardness, water conditions, and transducer installation. Units will typically read to deeper depths in fresh water than in salt water.

## WHAT'S ON THE DISPLAY

The HDR 610 uses a backlit 7-segment display, together with a 3-button keypad, to control all user functions. At initial power-up, the unit will begin normal operation and display the digital depth and the units of measure. The figure shows a typical view you might see on the display at initial power-up.



## KEY FUNCTIONS

Your HDR 610 uses three bezel keys to control the Shallow Alarm, Deep Alarm, Keel Offset, and Units of Measure functions. These three keys are the SET, UP Arrow, and DOWN Arrow keys. While in normal operating mode, pressing the SET key selects a function and causes a corresponding indicator to blink on the display. Once you have selected a function, you may adjust its setting by pressing the UP and DOWN Arrow keys. Additional presses of the SET key will sequentially select the other functions for adjustment. All user settings are remembered by the HDR 610, even after it has been powered off and back on again.

When in an active function, a single press to an Arrow key will result in a single incremental adjustment. Pressing and holding an Arrow key will sequence through a range of adjustments. If no adjustment is made for 5 seconds, the unit will return to normal operation.

## SHALLOW ALARM

The Shallow Alarm function can be set for depths ranging from 1 to 20 feet, and sounds an alarm when the depth measured is less than the setting.



1. While in normal operation mode, press the SET key once to display the Shallow Alarm setting and to cause the Shallow icon to blink.
2. Use the UP Arrow key to activate the Shallow Alarm and also to increase the selected value. Use the DOWN Arrow key to reduce the value. Press and hold the UP Arrow key until you reach the desired depth setting.

**NOTE:** The maximum Shallow Alarm setting cannot meet or exceed the current Deep Alarm setting (see Deep Alarm section).

3. After your selection is made, wait 5 seconds for the unit to return to normal operation. The Shallow icon should now be visible.



"SHALLOW" icon

4. If the depth of the water is less than the selected value, the alarm will sound and the Shallow icon will blink to indicate the alarm state. Pressing any key will mute the alarm; pressing the SET key will mute the alarm and activate the Shallow Alarm function for additional adjustment. To permanently turn the alarm off, use the DOWN Arrow key to return the display to Off.

## DEEP ALARM

The Deep Alarm function can be set for depths up to 99 feet, and sounds an alarm when the depth measured is greater than the setting.

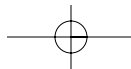

1. While in normal operation mode, press the SET key until the Deep Alarm setting is displayed and the Deep icon is blinking.
2. Use the UP Arrow key to activate the Deep Alarm and also to increase the selected value. Use the DOWN Arrow key to reduce the value. Press and hold the UP Arrow key until you reach the desired depth setting.

**NOTE:** The minimum Deep Alarm setting cannot meet or drop below the current Shallow Alarm setting (see Shallow Alarm section).

3. After your selection is made, wait 5 seconds for the unit to return to normal operation. The Deep icon should now be visible.



"DEEP" icon

4. If the depth of the water is greater than the selected value, the alarm will sound and the Deep icon will blink to indicate the alarm state. Pressing any key will mute the alarm; pressing the SET key will mute the alarm and activate the Deep Alarm function for additional adjustment. To permanently turn the alarm off, use the DOWN Arrow key to return the display to Off.

## UNITS

The Units control function selects the units of measure for depth readout and alarm functions. The three settings available are: Feet, Meters or Fathoms.

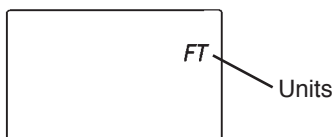

1. While in normal operation mode, press the SET key until Units is displayed and the Units icon is blinking.
2. Use either Arrow key to view the unit choices until you reach the desired unit: FT for feet, M for meters, FA for fathoms.

3. After your selection is made, wait 5 seconds for the unit to return to normal operation. The selected Units icon should now be visible.

Selected units icon



## KEEL OFFSET

The Keel Offset function adjusts the digital depth readout to display depth readings from either the waterline or the keel (lowest point of the boat), instead of from the location of the transducer (which is usually somewhere in between). This function lets you display transducer location and depth readouts suited to your needs.

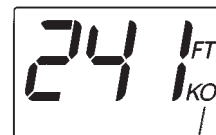

Keel Offset icon

1. To determine the value to enter into the Keel Offset setting, first decide whether depth from the waterline or depth from the keel is desired. Measurements will need to be made for the location desired.
- 2a. For depth from the keel of the boat, accurately measure the vertical distance between the face of the transducer and the keel of the boat. You will then need to enter this measurement into the Keel Offset function as a negative (-) number.

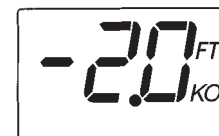

Or...

- 2b. For depth measurements from the waterline, accurately measure the vertical distance between the face of the transducer and the waterline of the boat. You will then need to enter this measurement into the Keel Offset function as a positive (+) number.



3. To enable Keel Offset, press the SET key until the KO icon is displayed on the screen.
4. The available settings are +10 to -10 units. The default setting of the unit is Off, which is displayed as zero (0.0). From the default setting of 0.0, use the DOWN Arrow key to enter a negative (-) number (for depth measurements from the keel of the boat); use the UP Arrow key to enter a positive (+) number (for depth measurements from the waterline).
5. After your selection is made, wait 5 seconds for the unit to return to normal operation. The KO icon should now be visible.

**EXAMPLE:** The following figures depict a scenario where the Keel Offset has been set to -2 feet. The third figure shows the return to normal operation with the updated depth readout.



Keel Offset icon

## MAINTENANCE

To keep both your HDR 610 and your transducer working properly, perform the following maintenance tasks as needed.

### HDR 610 MAINTENANCE

If your HDR 610 unit comes into contact with salt spray, simply wipe the affected surfaces with a cloth dampened in fresh water. Do not use a chemical glass cleaner on the lens, as chemicals in the solution may cause cracking in the lens. When cleaning the LCD protective lens, use a chamois and non-abrasive, mild cleaner. Do not wipe while dirt or grease is on the lens. Be careful to avoid scratching the lens.

**WARNING:** Never leave your HDR 610 in a closed car or trunk; the extremely high temperatures generated in hot weather can damage the electronics.

### TRANSDUCER MAINTENANCE

If your boat remains in the water for long periods of time, algae and other marine growth can reduce the effectiveness of the transducer. Periodically clean the face of the transducer with hot water. Pivoting the transducer up in the bracket may allow better access for inspection or cleaning.

If your boat remains out of the water for a long period of time, it may take some time to wet the transducer after it is returned to the water. Small air bubbles can cling to the surface of the transducer and interfere with proper operation. These bubbles will dissipate with time, or you may wipe the face of the transducer with your fingers after the transducer is in the water.

## TROUBLESHOOTING

Before contacting the Humminbird® Customer Resource Center, please read the following section. Taking the time to review these troubleshooting guidelines may allow you to solve a performance problem yourself, and therefore avoid sending your unit back for repair.

**NOTE:** Do not attempt to repair the HDR 610 yourself, as there are no user serviceable parts inside, and special tools and techniques are required for reassembly in order to maintain the waterproof integrity of the housing. Repairs should be performed only by authorized Humminbird® technicians.



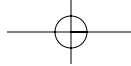

## HDR 610 Doesn't Power Up

If your HDR 610 doesn't power up, refer to the Installation section, and make sure that:

- the power cable is properly connected to the HDR 610;
- the power cable is wired correctly, with red to positive battery terminal and black to negative terminal or ground;
- the fuse is operational; a fuse can often appear to be good when in fact it is not; check the fuse with a tester or replace it with a known good fuse;
- if the unit is wired through a fuse panel, make sure that the panel is powered, as accessory fuse panels are often controlled by a separate switch, or even the ignition switch of the boat;
- the battery voltage of the power connector is between 10 and 16 VDC.

Correct any known problems, including removing corrosion from the battery terminals or wiring, or actually replacing the battery if necessary.

## No Bottom Reading on the Display

If there is no bottom reading visible on the display, there are a number of possible causes for this condition, including:

- if the loss of bottom information occurs only at high boat speeds, then a transducer adjustment may be needed (refer to the Transducer Installation section);
- check the transducer cable connection on the back of the HDR 610 and make sure that the cable to the transducer has not been cut or pinched, as even a small abrasion in the cable can affect performance significantly.

Correct any known problems, including adjusting the transducer, or actually replacing the transducer cable if necessary.

## No Continuous Depth Display in Very Shallow Water

Losing continuous depth when the boat is in very shallow water is normal, because the automatic range control cannot lock onto the bottom in depths of one foot or less.

## Screen Fades, Images Are Not Sharp

If the screen begins to fade, and images are not as sharp as normal, check the input voltage. The HDR 610 will not operate on input voltages below 10 VDC.

## Bottom Reading Disappears During a Hard Turn

Losing the bottom reading temporarily when the boat is executing a hard turn is normal, as the transducer emerges from the water during such a turn; this condition should correct itself once the turn is completed.

## 1-YEAR LIMITED WARRANTY

We warrant the original retail purchaser that products made by Humminbird® have been manufactured free from defects in materials and workmanship. This warranty is effective for one year from the date of original retail purchase. Humminbird® products found to be defective and covered by this warranty will be replaced or repaired free of charge at Humminbird® option and returned to the customer freight prepaid. Humminbird® sole responsibility under this warranty is limited to the repair or replacement of a product that has been deemed defective by Humminbird®. Humminbird® is not responsible for charges connected with the removal of such product or reinstallation of replaced or repaired parts.

This warranty does not apply to a product that has been:

- Improperly installed;
- Used in an installation other than that recommended in the product installation and operation instructions;
- Damaged or has failed because of an accident or abnormal operation;
- Repaired or modified by entities other than Humminbird®.

Please retain your original receipt as a proof of the purchase date. This will be required for in-warranty service.

THIS WARRANTY IS EXPRESSLY IN LIEU OF ANY OTHER WARRANTIES, OBLIGATIONS OR LIABILITIES ON THE PART OF HUMMINBIRD® AND WILL BE THE CUSTOMER'S EXCLUSIVE REMEDY, EXCEPT FOR ANY APPLICABLE IMPLIED WARRANTIES UNDER STATE LAW WHICH ARE HEREBY LIMITED IN DURATION TO ONE YEAR FROM THE DATE OF ORIGINAL PURCHASE. IN NO EVENT WILL HUMMINBIRD® BE LIABLE FOR ANY INCIDENTAL OR CONSEQUENTIAL DAMAGES FOR BREACH OF ANY EXPRESS OR IMPLIED WARRANTY RELATING TO THE PRODUCTS.

Some states do not allow limitations on an implied warranty, or the exclusion of incidental or consequential damages, so the above exclusions may not apply to you. You may also have other rights, which vary from state to state.

## HUMMINBIRD® SERVICE POLICY

Even though you'll probably never need to take advantage of our incredible service policy, it's good to know that we back our products this confidently. We do it because you deserve the best. We will make every effort to repair your unit within three business days from the receipt of your unit at our factory. This does not include shipping time to and from our factory. Units received on Friday are typically shipped by the following Wednesday, units received Monday are typically shipped by Thursday, etc.

All repair work is performed by factory-trained technicians to meet exacting factory specifications. Factory-serviced units go through the same rigorous testing and quality control inspections as new production units.

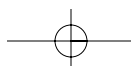



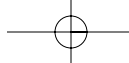

After the original warranty period, a standard flat rate service charge will be assessed for each repair (physical damage and missing parts are not included). Any repairs made after the original warranty will be warranted for an additional 90 days after service has been performed by our factory technicians. You can contact our Customer Resource Center or visit our website to verify the flat rate repair fee for your product (visit the Product Support section):

<http://www.humminbird.com>

We reserve the right to deem any product unserviceable when replacement parts are no longer available or impossible to obtain. This Service Policy is valid in the United States only. This applies only to Humminbird® products returned to our factory in Eufaula, Alabama. This Service Policy is subject to change without notice.

### Returning Your Unit for Service

Before sending your unit in for repair, please contact the factory, either by phone or by email, to obtain a Repair Authorization Number for your unit. Please have your product model name and serial number available before calling the factory. If you contact the factory by e-mail, please include your product model name and serial number in the e-mail, and use Request for Repair Authorization Number for your e-mail subject header. You should include your Repair Authorization Number in all subsequent communications about your unit.

#### **For IN-WARRANTY service, complete the following steps:**

- Obtain a Repair Authorization Number from the Humminbird® Customer Resource Center.
- Tag product with your name, street address, phone number and your assigned Repair Authorization Number.
- Include a brief written description of the problem.
- Include a copy of your receipt (to show proof and date of purchase).
- Return product freight prepaid to Humminbird®, using an insured carrier with delivery confirmation.

#### **For OUT-OF-WARRANTY service, complete the following steps:**

- Obtain a Repair Authorization Number from the Humminbird® Customer Resource Center.
- Include payment in the form of credit card number and expiration date, money order or personal check. Please do not send cash.
- Tag product with your name, street address, phone number and your assigned Repair Authorization Number.
- Include a brief written description of the problem.
- Return product freight prepaid to Humminbird®, using an insured carrier with delivery confirmation.

## SPECIFICATIONS

Depth Capability.....	600 ft (180 m)
Power Cable Length.....	36" (91 cm)
Operating Frequency.....	200 kHz
Area of Coverage.....	16° @ -10 dB
Power Requirement.....	10-16 VDC
Display.....	Liquid Crystal Diode (LCD)
Mounting.....	In-Dash 2 1/8" hole
Unit Housing.....	High-Impact Plastic
Transducer.....	(transom mount) XHS 9 20 ..... (puck) XP 9 20
Transducer Cable Length.....	20 ft (6 m)

**NOTE:** Humminbird® verifies maximum stated depth in saltwater conditions, but actual depth performance may vary due to transducer installation, water type, thermal layers, bottom composition and slope.

**NOTE:** Product specifications and features are subject to change without notice.

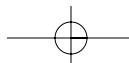

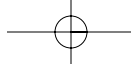

## CONTACT HUMMINBIRD®

Contact the Humminbird® Customer Resource Center  
in any of the following ways:

By Telephone  
(Monday - Friday 8:00 a.m. to 4:30 p.m. Central Standard Time):

**1-800-633-1468**

By e-mail  
(typically we respond to your e-mail within three business days):

[custserv@johnsonoutdoors.com](mailto:custserv@johnsonoutdoors.com)

For direct shipping, our address is:

**Humminbird  
Service Department  
678 Humminbird Lane  
Eufaula, AL 36027 USA**

**WARNING!** Do not touch an active transducer during operation, as this may cause physical discomfort and may result in personal injury in the form of tissue damage. Handle the transducer only when the power to the fishfinder is off.

**WARNING!** This device should not be used as a navigational aid to prevent collision, grounding, boat damage, or personal injury. When the boat is moving, water depth may change too quickly to allow time for you to react. Always operate the boat at very slow speeds if you suspect shallow water or submerged objects.

**WARNING!** Disassembly and repair of this electronic unit should only be performed by authorized service personnel. Any modification of the serial number or attempt to repair the original equipment or accessories by unauthorized individuals will void the warranty. For products manufactured prior to July 1, 2006, handling and/or opening this unit may result in exposure to lead, in the form of solder.

**WARNING!** Products manufactured prior to July 1, 2006 contain lead, a chemical known to the state of California to cause cancer, birth defects and other reproductive harm.

## TRANSOM MOUNT TRANSDUCER MOUNTING TEMPLATE

Use the template (top graphic) to determine mounting hole location, and the bottom angle guide to determine transducer bottom angle.

