

## Trolling Motor Choke

531711-1\_C

### Thank You

Thank you for choosing Humminbird®, the #1 name in fishfinders. Humminbird® has built its reputation by designing and manufacturing top-quality, thoroughly reliable marine equipment. Genuine Humminbird® accessories offer the opportunity to upgrade and expand the capabilities of your Humminbird® product.

Your Humminbird® is designed for trouble-free use in even the harshest marine environment. In the unlikely event that your Humminbird® does require repairs, we offer an exclusive Service Policy - free of charge during the first year after purchase, and available at a reasonable rate after the one-year period. For complete details, see the Warranty section included in this manual.

Contact our Customer Resource Center at **1-800-633-1468** or visit our Web site at [humminbird.com](http://humminbird.com).

### Installation Overview

Following are instructions for the installation of this accessory. Before you start installation, we encourage you to read these instructions carefully in order to get the full benefit from your Humminbird® accessory.

If you find that any items are missing from your installation kit, call our Customer Resource Center at **1-800-633-1468** or visit our Web site at [humminbird.com](http://humminbird.com).

***NOTE:** This installation requires cutting wires; therefore, installation should be performed by a qualified marine technician.*

### Trolling Motor Choke Installation

Perform the procedures in the following sections to install the Trolling Motor Choke on your boat.

**Supplies:** In addition to the hardware supplied with the Trolling Motor Choke, you will need various hand tools, including a wire cutter and stripper, crimp tool (12-10 gauge, yellow), and a hot air gun.

#### 1. Locating the Mounting Position

You must first determine the best location to mount the Trolling Motor Choke. For best performance, choose the mounting location that corresponds with your trolling motor.

- **Motor Base Mount:** For trolling motors where the power line comes out of the motor base (for example: Minn Kota® Terrova), the Trolling Motor Choke should be hard mounted to the boat.
  - Select a location where the Trolling Motor Choke can be hard mounted to the boat that is also as close as practical to the motor base.
- **Foot Pedal Mount:** For trolling motors where the power line comes out of the foot pedal (for example: Minn Kota® Maxxum), the Trolling Motor Choke should be mounted as close to the foot pedal as possible and located in one of the following two locations:
  - Select a location in the recessed foot pedal compartment so that the Trolling Motor Choke can be tucked out of the way, or
  - Select a location on deck that is between the foot pedal and the trolling motor.

**Crimp Tool**

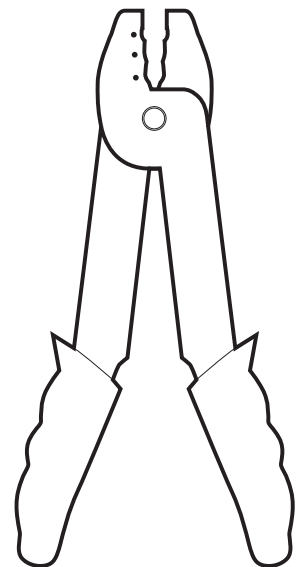

## Trolling Motor Choke

531711-1\_C

### 2. Installing the Trolling Motor Choke

Install the Trolling Motor Choke using the following procedures.



**DANGER! Electrocution Hazard! Failure to disconnect power may lead to serious injury.** Before you begin installation, remove the power supply from the trolling motor: Turn OFF the trolling motor breaker, disconnect battery wires, and remove the fuse. It is important to confirm that there isn't voltage before you proceed with the following installation.

1. Confirm that all power is disconnected from the trolling motor: Turn OFF the trolling motor breaker, disconnect the battery wires, and remove the fuse.

2a. **Motor Base Mount:** Route the trolling motor power line to the Trolling Motor Choke mounting location chosen in Section 1 (**Locating the Mounting Position**). Cut the trolling motor power line at the point where it easily meets the trolling motor choke mounting location. **Do NOT cut the foot pedal cable connector.** See illustration.

*NOTE: The Trolling Motor Choke will be hard mounted in a later step.*

2b. **Foot Pedal Mount:** Cut the trolling motor power line approximately 4" from the foot pedal. **Do NOT cut the steer cable.** See illustration.

3. Place the Trolling Motor Choke in the selected mounting location between the cut wires. The short end of the Trolling Motor Choke wires should be placed closest to the motor base (for Motor Base Mount) or to the foot pedal (for Foot Pedal Mount). See illustrations.

4. Strip back the cable insulation 1/4" on each side of the cut wires.

5. Slide the Heat Shrink Tubes (included) over the Trolling Motor Choke wires. Push the Heat Shrink Tubes past the connection points until you are ready to use them in the following steps.

6. Insert the cut wires into the Trolling Motor Choke's hollow metal connectors, connecting positive to positive (red) and negative to negative (black). Use a standard crimp tool (12-10 gauge, yellow) to crimp the connectors onto the wires. Make sure the connectors are closed completely.

*NOTE: Do NOT use pliers for crimping.*

7. Slide the Heat Shrink Tubes over the four wire connection points. Heat shrink each connection.

Sliding the Heat Shrink Tubes over the Trolling Motor Choke Wires

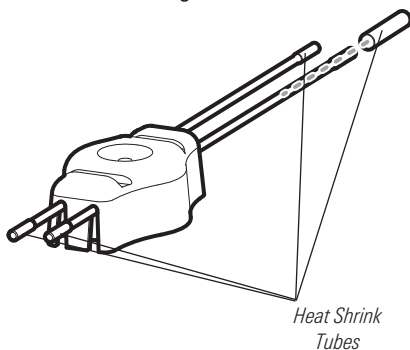

Applying Heat Shrink

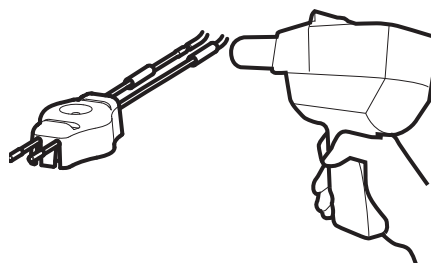

Motor Base Mount

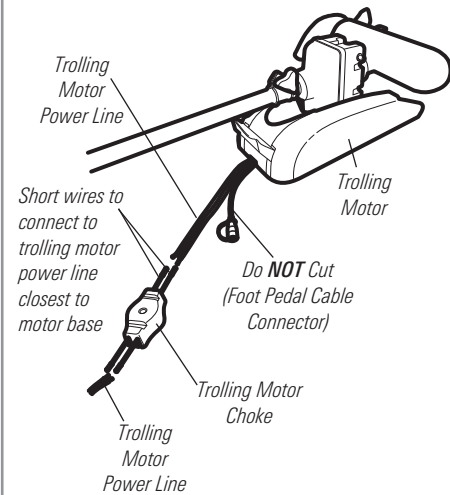

Foot Pedal Mount

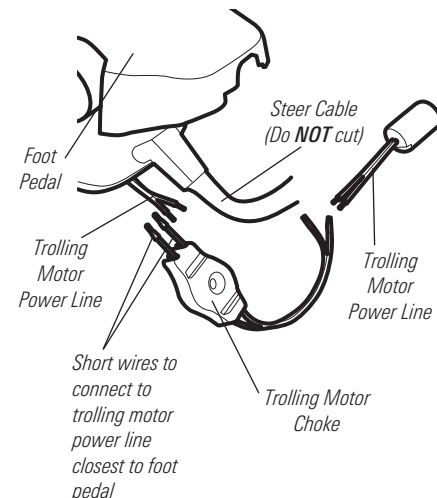

Installing the Mounting Screw and Washer

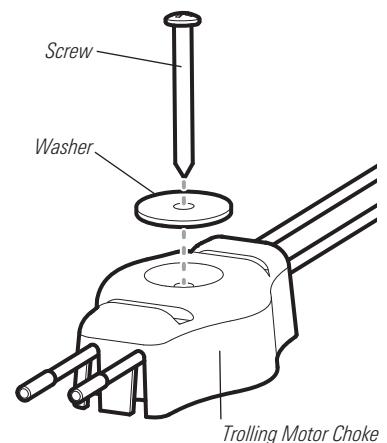

8. To secure the Trolling Motor Choke mounting location, install the included screw and washer through the Trolling Motor Choke into the deck or use zip ties (included) to secure as needed.

## Trolling Motor Choke

531711-1\_C

### For Best Performance

Make sure the power cables and transducer cables are separated, not tied, tangled, or piled on top of each other. It is important to coil the cables neatly and separate them as much as possible.

### Humminbird® Customer Resource Center

If you find that any items are missing from your installation kit, or you need additional assistance, call our Customer Resource Center at **1-800-633-1468** or visit our Web site at [humminbird.com](http://humminbird.com).

### 1-Year Limited Warranty

We warrant the original retail purchaser that products made by Humminbird® have been manufactured free from defects in materials and workmanship. This warranty is effective for one year from the date of original retail purchase. Humminbird® products found to be defective and covered by this warranty will be repaired or replaced free of charge at Humminbird® option and returned to the customer freight prepaid. Humminbird® sole responsibility under this warranty is limited to the repair or replacement of a product that has been deemed defective by Humminbird®. Humminbird® is not responsible for charges connected with the removal of such product or reinstallation of replaced or repaired parts.

This warranty does not apply to a product that has been:

- Improperly installed;
- Used in an installation other than that recommended in the product installation and operation instructions;
- Damaged or has failed because of an accident or abnormal operation;
- Repaired or modified by entities other than Humminbird®.

Please retain your original receipt as a proof of the purchase date. This will be required for in-warranty service.

THIS WARRANTY IS EXPRESSLY IN LIEU OF ANY OTHER WARRANTIES, OBLIGATIONS OR LIABILITIES ON THE PART OF HUMMINBIRD® AND WILL BE THE CUSTOMER'S EXCLUSIVE REMEDY, EXCEPT FOR ANY APPLICABLE IMPLIED WARRANTIES UNDER STATE LAW WHICH ARE HEREBY LIMITED IN DURATION TO ONE YEAR FROM THE DATE OF ORIGINAL PURCHASE. IN NO EVENT WILL HUMMINBIRD® BE LIABLE FOR ANY INCIDENTAL OR CONSEQUENTIAL DAMAGES FOR BREACH OF ANY EXPRESS OR IMPLIED WARRANTY RELATING TO THE PRODUCTS.

Some states do not allow limitations on an implied warranty, or the exclusion of incidental or consequential damages, so the above exclusions may not apply to you. You may also have other rights, which vary from state to state.

### Humminbird® Service Policy

Even though you'll probably never need to take advantage of our incredible service policy, it's good to know that we back our products this confidently. We do it because you deserve the best. We will make every effort to repair your unit within three business days from the receipt of your unit at our factory. This does not include shipping time to and from our factory. Units received on Friday are typically shipped by the following Wednesday, units received Monday are typically shipped by Thursday, etc.

All repair work is performed by factory-trained technicians to meet exacting factory specifications. Factory-serviced units go through the same rigorous testing and quality control inspections as new production units.

After the original warranty period, a standard flat rate service charge will be assessed for each repair (physical damage and missing parts are not included). Any repairs made after the original warranty will be warranted for an additional 90 days after service has been performed by our factory technicians. You can contact our Customer Resource Center or visit our Web site to verify the flat rate repair fee for your product (visit the Product Support section):

<http://www.humminbird.com>

We reserve the right to deem any product unserviceable when replacement parts are no longer available or impossible to obtain. This Service Policy is valid in the United States only. This applies only to Humminbird® products returned to our factory in Eufaula, Alabama. This Service Policy is subject to change without notice.

For Best Performance:  
Coil Cables Neatly

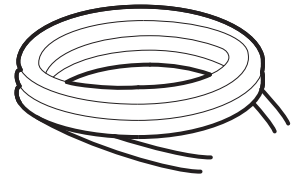

**DOMESTIC (USA) CUSTOMERS:**  
**PLEASE DO NOT RETURN THIS PRODUCT TO STORE FOR SERVICE**

For all technical issues please call **1-800-633-1468**  
or visit [humminbird.com](http://humminbird.com), click **SUPPORT**.  
Please reference product serial number and  
model number when contacting Humminbird®.

## Trolling Motor Choke

531711-1\_C

### Returning Your Unit for Service

Before sending your unit in for repair, please contact the factory, either by phone or by email, to obtain a Repair Authorization Number for your unit.

**NOTE:** Please do not return your Humminbird® to the store for service.

Please have your product model name and serial number available before calling the factory. If you contact the factory by e-mail, please include your product model name and serial number in the e-mail, and use Request for Repair Authorization Number for your e-mail subject header. You should include your Repair Authorization Number in all subsequent communications about your unit.

#### For IN-WARRANTY service, complete the following steps:

- Obtain a Repair Authorization Number from the Humminbird® Customer Resource Center.
- Tag product with your name, street address, phone number, and your assigned Repair Authorization Number.
- Include a brief written description of the problem.
- Include a copy of your receipt (to show proof and date of purchase).
- Return product freight prepaid to Humminbird®, using an insured carrier with delivery confirmation.

#### For OUT-OF-WARRANTY service, complete the following steps:

- Obtain a Repair Authorization Number from the Humminbird® Customer Resource Center.
- Include payment in the form of credit card number and expiration date, or a money order. Please do not send cash.
- Tag product with your name, street address, phone number, and your assigned Repair Authorization Number.
- Include a brief written description of the problem.
- Return product freight prepaid to Humminbird®, using an insured carrier with delivery confirmation.

### Contact Humminbird®

Contact the Humminbird® Customer Resource Center in any of the following ways:

#### By Telephone

(Monday - Friday 8:00 a.m. to 4:30 p.m. Central Standard Time):

1-800-633-1468

#### By e-mail

(typically we respond to your e-mail within three business days):

[service@humminbird.com](mailto:service@humminbird.com)

For direct shipping, our address is:

**Humminbird  
Service Department  
678 Humminbird Lane  
Eufaula, AL 36027 USA**

**WARNING!** This device should not be used as a navigational aid to prevent collision, grounding, boat damage, or personal injury. When the boat is moving, water depth may change too quickly to allow time for you to react. Always operate the boat at very slow speeds if you suspect shallow water or submerged objects.

**WARNING!** Disassembly and repair of this electronic unit should only be performed by authorized service personnel. Any modification of the serial number or attempt to repair the original equipment or accessories by unauthorized individuals will void the warranty.

**WARNING!** This product contains chemicals known to the State of California to cause cancer and/or reproductive harm.

**WEEE Directive:** EU Directive 2002/96/EC "Waste of Electrical and Electronic Equipment Directive (WEEE)" impacts most distributors, sellers, and manufacturers of consumer electronics in the European Union. The WEEE Directive requires the producer of consumer electronics to take responsibility for the management of waste from their products to achieve environmentally responsible disposal during the product life cycle.

WEEE compliance may not be required in your location for electrical & electronic equipment (EEE), nor may it be required for EEE designed and intended as fixed or temporary installation in transportation vehicles such as automobiles, aircraft, and boats. In some European Union member states, these vehicles are considered outside of the scope of the Directive, and EEE for those applications can be considered excluded from the WEEE Directive requirement.



This symbol (WEEE wheelee bin) on product indicates the product must not be disposed of with other household refuse. It must be disposed of and collected for recycling and recovery of waste EEE.

Johnson Outdoors Marine Electronics, Inc. will mark all EEE products in accordance with the WEEE Directive. It is our goal to comply in the collection, treatment, recovery, and environmentally sound disposal of those products; however, these requirements do vary within European Union member states. For more information about where you should dispose of your waste equipment for recycling and recovery and/or your European Union member state requirements, please contact your dealer or distributor from which your product was purchased.